

Technical Data

Specifications & Capacities

RTC 8065

Series II
Telescopic Boom Rough Terrain Crane
65 ton (60.0 metric ton)

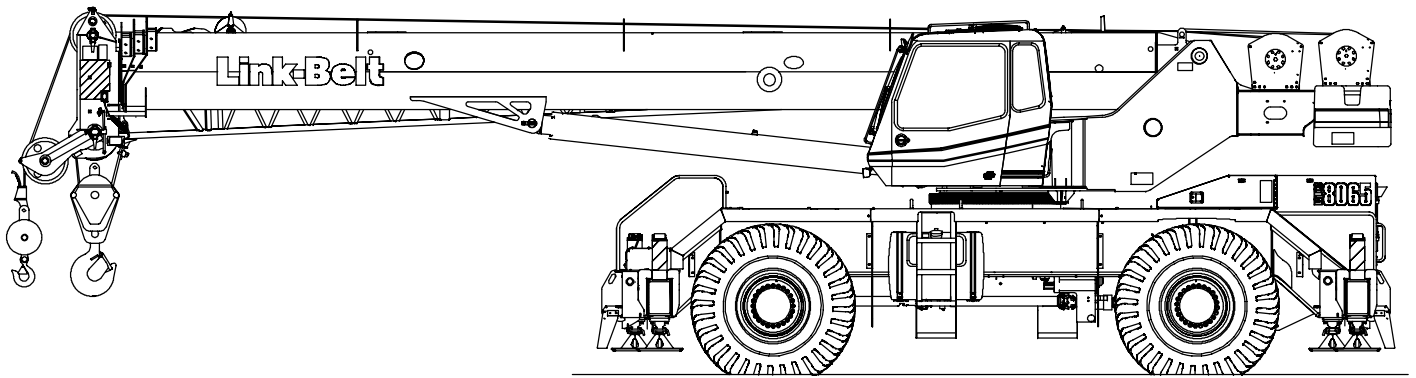

CAUTION: This material is supplied for reference use only. Operator must refer to in-cab Crane Rating Manual and Operator's Manual to determine allowable crane lifting capacities and assembly and operating procedures.

Table Of Contents

Boom, Attachments, and Upper Structure	1
Boom	1
Boom Head	1
Boom Elevation	1
Auxiliary Lifting Sheave – Optional	1
Hook Blocks and Balls – Optional	1
Fly – Optional	1
Fly Inserts – Optional	1
Operator’s Cab and Controls	1
Swing	2
Electrical	2
Load Hoist System	3
Load Hoist Performance	3
2M Main and Optional Auxiliary Winches	3
Hydraulic System	3
Counterweight	3
Carrier	4
General	4
Outriggers	4
Steering and Axles	4
Suspension	4
Tires and Wheels	4
Brakes	4
Electrical	4
Engine	4
Transmission	4
Carrier Speeds and Gradeability	5
Fuel Tank	5
Hydraulic System	5
Pump Drive	5
Axle Loads	6
General Dimensions	7
Working Range Diagram	8
Boom Extend Modes	9
Main Boom Lift Capacity Charts – Standard	10
Fully Extended Outriggers – 360° Rotation	10
On Tires – Stationary – Boom Centered Over Front Between Tire Tracks	11
On Tires – Pick & Carry (Creep) – Boom Centered Over Front	12
On Tires – Stationary – 360° Rotation	12
Fly Attachment Lift Capacity Charts – Optional	13
Fully Extended Outriggers – 360° Rotation	13
115 ft Main Boom Length – 2° Fly Offset	13
115 ft Main Boom Length – 15° Fly Offset	13
115 ft Main Boom Length – 30° Fly Offset	14
115 ft Main Boom Length – 45° Fly Offset	14

Main Boom Lift Capacity Charts – Metric	15
Fully Extended Outriggers – 360° Rotation	15
On Tires – Stationary – Boom Centered Over Front Between Tire Tracks	16
On Tires – Pick & Carry (Creep) – Boom Centered Over Front	17
On Tires – Stationary – 360° Rotation	17
Fly Attachment Lift Capacity Charts – Optional	18
Fully Extended Outriggers – 360° Rotation	18
35.05 m Main Boom Length – 2° Fly Offset	18
35.05 m Main Boom Length – 15° Fly Offset	18
35.05 m Main Boom Length – 30° Fly Offset	19
35.05 m Main Boom Length – 45° Fly Offset	19

Boom, Attachments, and Upper Structure

■ Boom

Design – Four section, formed construction of extra high tensile steel consisting of one base section and three telescoping sections. The first telescoping section extends independently by means of one double-acting, single stage hydraulic cylinder with integrated holding valves. The second and third telescoping sections extend proportionally by means of one double-acting, single stage cylinder with integrated holding valves and cables.

Boom

- 38 ft–115 ft (11.6–35.0m) four section full power boom
- Two mode boom extension: *A-max* mode provides superior capacities by extending the first telescoping section to 63 ft 8 in (19.4m). Standard mode synchronizes all the telescoping sections proportionally to 115 ft (35.0m). Controlled from the operator's cab.
- Mechanical boom angle indicator
- Maximum tip height for *A-max* mode is 73 ft 6 in (22.4m) and standard mode is 123 ft 9 in (37.7m).

Boom Head

- Four 16.5 in (41.9cm) root diameter nylon sheaves to handle up to eight parts of line
- Easily removable wire rope guards
- Rope dead end lugs on each side of the boom head
- Boom head is designed for quick-reeve of the hook block

Boom Elevation

- One double acting hydraulic cylinder with integral holding valve
- Boom elevation: -3° to 78°

Auxiliary Lifting Sheave – Optional

- Single 16.5 in (41.9m) root diameter nylon sheave
- Easily removable wire rope guards
- Does not affect erection of the fly or use of the main head sheaves

Hook Blocks and Balls – Optional

- 40 ton (36.3mt) 4 sheave quick-reeve hook block with safety latch
- 60 ton (54.4mt) 4 sheave quick-reeve hook block with safety latch
- 70 ton (63.5mt) 5 sheave quick-reeve hook block with safety latch
- 8.5 ton (7.7mt) swivel and non-swivel hook balls with safety latch

Fly – Optional

- 35 ft (10.7m) one piece lattice fly, stowable, offsettable to 2° , 15° , 30° , and 45° . Maximum tip height is 158 ft (48.2m).
- 35 ft–58 ft (10.7–17.7m) two piece bi-fold lattice fly, stowable, offsettable to 2° , 15° , 30° , and 45° . Maximum tip height is 180 ft 5 in (55.0m).

Fly Inserts – Optional

- One 16 ft (4.9m) lattice insert, equipped with two 16.5 in (41.9cm) root diameter nylon sheaves, to be mounted between the boom head and fly options. Maximum tip height is 196 ft (59.7m).
- Two 16 ft (4.9m) lattice inserts, one equipped with two 16.5 in (41.9cm) root diameter nylon sheaves, to be mounted between the boom head and fly options. Maximum tip height is 211 ft 7 in (64.5m).

■ Operator's Cab and Controls

Environmental Cab – Fully enclosed, one person cab of galvaneal steel structure with acoustical insulation
Equipped with:

- Tinted and tempered glass windows
- Extra-large fixed front window with windshield wiper and washer
- Swing up roof window with windshield wiper
- Sliding left side door with large fixed window
- Sliding rear and right side windows for ventilation
- Six way adjustable, cushioned seat with seat belt and storage compartment
- Engine dependent warm-water heater with air ducts for front windshield defroster and cab floor
- Defroster fan for the front window
- Bubble level
- Circulating fan
- Adjustable sun visor
- Dome light
- Cup holder
- Fire extinguisher
- Left side viewing mirror
- Two position travel swing lock

Air Conditioning – Optional – Integral with cab heating system utilizing the same ventilation outlets

Steering Column – Pedestal type with tilt and telescope functions for operator comfort. Column includes the following controls and indicators:

Left and right levers include:

- Horn button
- Turn signal switch
- Driving light switch
- Transmission direction switch

Panel mounted switches for:

- Travel park brake
- Steer mode selector
- 2/4 wheel drive/range selector
- Transmission gear selector

- Hazard flasher

Panel mounted indicator/warning lights for:

- Transmission temperature
- Engine oil pressure
- Travel park brake
- Service brake
- Turn signals
- Rear wheel offset – optional
- Emergency steer – optional

Armrest Controls – Two dual axis hydraulic joystick controllers or optional single axis hydraulic controllers for:

- Swing
- Boom hoist
- Main rear winch
- Auxiliary front winch – optional
- Drum rotation indication
- Drum rotation indicator activation switch
- Winch high/low speed and disable switch(es)
- Third wrap selector switch – optional
- Telescopic override switches
- Warning horn button
- Swing park brake

Outrigger Controls – Hand held control box with umbilical cord gives the operator the freedom to view operation while setting the outriggers.

Foot Controls

- Boom telescope
- Swing brake
- Engine throttle
- Service brake

Right Front Console – Controls and indicators for:

- | | |
|-------------------------------------|---|
| • Engine ignition | • Console dimmer switch |
| • Engine throttle lock | • Bubble level |
| • Function disable | • 12 volt power connection |
| • Front windshield wiper and washer | • Air conditioning – optional |
| • Cab floodlights | • Boom floodlight – optional |
| • Warning horn | • Rotating beacon/Strobe light – optional |
| • Heating controls | • Third wrap indicator – optional |

Cab Instrumentation – Ergonomically positioned, analog instrumentation for crane operation including:

- Engine coolant temperature with warning indicator
- Hydraulic oil temperature with warning indicator
- Fuel level with warning indicator
- Tachometer
- Transmission temperature with warning indicator
- Voltmeter with warning indicator

Rated Capacity Limiter – Microguard graphic audio–visual warning system integrated into the dash with anti–two block and function limiter. Operating data available includes:

- Crane configuration
- Boom length and angle
- Boom head height
- Allowed load and % of allowed load
- Boom angle
- Radius of load
- Actual load
- Operator settable alarms (include):
 - Maximum and minimum boom angles
 - Maximum tip height
 - Maximum boom length
 - Swing left/right positions
 - Operator defined area (imaginary plane)

Internal RCL Light Bar – Optional – Visually informs the operator when crane is approaching maximum load capacity with a series of green, yellow, and red lights.

External RCL Light Bar – Optional – Visually informs the ground crew when crane is approaching maximum load capacity with a series of green, yellow, and red lights.

■ Swing

Motor/Planetary – Bi–directional hydraulic swing motor mounted to a planetary reducer for 360° continuous smooth swing at 2.0 rpm

Swing Park Brake – 360°, electric over hydraulic, (spring applied/hydraulic released) multi–disc brake mounted on the speed reducer. Operated by a switch from the operator’s cab.

Swing Brake – 360°, foot operated, hydraulic applied disc brake mounted to the speed reducer

Swing Lock – Two–position swing lock (boom over front or rear) operated from the operator’s cab

360° Positive Swing Lock – Optional – Meets New York City requirement

■ Electrical

Swing Alarm – Audio warning device signals when the upper is swinging.

Lights

- Two working lights on front of the cab
- One rotating amber beacon on top of the cab – optional
- One amber strobe beacon on top of the cab – optional
- Boom floodlight – optional

■ Load Hoist System

Load Hoist Performance

Main (Rear) and Auxiliary (Front) Winches – 3/4 in (19mm) Rope										
Layer	Maximum Line Pull		Normal Line Speed		High Line Speed		Layer		Total	
	lb	kg	ft/min	m/min	ft/min	m/min	ft	m	ft	m
1	17,182	7 793.6	171	52.1	322	98.1	86	26.2	86	26.2
2	15,523	7 041.1	190	57.9	356	108.5	96	29.3	182	55.5
3	14,157	6 421.5	208	63.4	390	118.9	105	32.0	287	87.5
4	13,011	5 901.7	226	68.9	425	129.5	114	34.7	401	122.2
5	12,038	5 460.3	245	74.7	459	139.9	123	37.5	524	159.7
6	---	---	---	---	---	---	133	40.5	657	200.3

Wire Rope Application		Diameter		Type	Maximum Permissible Load	
		in	mm		lb	kg
Main (Rear) Winch	Standard	3/4	19	6x19 IWRC – right regular lay (Type DB)	16,800	7 620.4
	Optional	3/4	19	18x19 rotation resistant – right regular lay (Type RB)	12,920	5 860.4
Auxiliary (Front) Winch	Standard	3/4	19	6x19 IWRC – right regular lay (Type DB)	16,800	7 620.4
	Optional	3/4	19	18x19 rotation resistant – right regular lay (Type RB)	12,920	5 860.4

2M Main and Optional Auxiliary Winches

- Axial piston, full and half displacement (2–speed) motors driven through planetary reduction unit for positive control under all load conditions
- Grooved lagging
- Power up/down mode of operation
- Drum rotation indicator(s)
- Drum diameter: 13 in (33.0cm)
- Rope length:
 - Front: 500 ft (152.4m)
 - Rear: 600 ft (182.9m)
- Maximum rope storage: 657 ft (200.3m)
- Terminator style socket and wedge
- Hoist drum cable followers – optional

Third wrap indicator – optional – Visually and audibly warns the operator when the wire rope is on the first/bottom layer and when the wire rope is down to the last three wraps

■ Hydraulic System

Counterbalance Valves – All hoist motors, boom extend cylinders, and boom hoist cylinders are equipped with counterbalance valves to provide load lowering and prevents accidental load drop when hydraulic power is suddenly reduced.

■ Counterweight

Total of 12,000 lb (5 443kg) of counterweight pinned to the upper structure frame with capacities for the 12,000 lb (5 443kg) configuration

Carrier

General

- 10 ft 7 in (3.22m) wide
- 14 ft 7 in (4.45m) wheelbase (centerline of first axle to centerline of second axle)

Frame – Box–type, torsion resistant, welded construction made of high tensile steel. Equipped with front and rear towing and tie–down lugs, tow connections, and access ladders.

Outriggers

Boxes – Two double box, front and rear welded to carrier frame

Beams and Jacks – Four single stage beams with Confined Area Lifting Capacities (CALC™) provide selectable outrigger extensions of full, intermediate, and retracted. Hydraulically controlled from the operator's cab with integral check valves.

Pontoons – Four lightweight, quick release, 23.5 x 23.5 in (59.7 x 59.7cm), steel pontoons with contact area of 460 in² (2 968cm²) can be stored for road travel in storage racks on the carrier.

Main Jack Reaction – 90,500 lb (41 050kg) force and 197 psi (1 358kPa) ground bearing pressure

Steering and Axles

Steering – Four independent modes consisting of two wheel front, two wheel rear, four wheel, and crab. Each mode is controlled from the steering wheel and is selected by a switch in the operator's cab.

Drive – Two modes: 4 x 2 and 4 x 4 for off highway travel

Axle 1 – Steered, non–driven for 4 x 2 and steered, driven for 4 x 4

Axle 2 – Steered, driven

Suspension

Front – Rigid mount to the carrier frame

Rear – The rear axle is suspended on the oscillation cylinders with motion of the axle controlled by a four bar linkage system. The oscillation cylinders lockout when the upper structure rotates 2.5° past centerline.

- Hydro–gas rear suspension – optional

Tires and Wheels

Front and Rear – Four (single) 26.5 x 25–26 ply rating, earthmover type tires on steel disc wheels

- Spare tires and wheels – optional

Brakes

Service – Full hydraulic, dual circuit, disc type brakes on all wheel ends

Parking/Emergency – Spring applied type, acting on front axle

Electrical

Two batteries provide 12 volt starting and operation

Lights

- Front lighting includes two main headlights and two parking/directional indicators.
- Side lighting includes two parking/directional indicators per side.
- Rear lighting includes two parking/directional indicators, two parking/brake lights, and two reversing lights.
- Other equipment includes hazard/warning system, cab light, instrument panel light, and signal horn.

Engine

Specification	CAT C6.6
Numbers of Cylinders	6
Cycle	4
Bore and Stroke: inch (mm)	4.13 x 5.00 (105 x 127)
Piston Displacement: in ³ (L)	403 (6.6)
Max. Brake Horsepower: hp (kW)	225 (167.8) @ 2,200 rpm
Peak Torque: ft lb (Nm)	727 (986) @ 1,400 rpm
Alternator: volts – amps	12 – 150
Crankcase Capacity: qt (L)	18.4 (17.4)
• Mechanically driven fan and thermostatically controlled radiator	

Transmission

Powershift – Three speed with high/low range for 6 forward and 6 reverse gears. Front axle disconnect for two or four wheel drive. Front axle disconnects in high range.

■ Carrier Speeds and Gradeability

Spicer		Speed		Gradeability (@ stall)	
Gear	Ratio	mph	km/h	% Grade	
6th	Forward & Reverse 2WD/Hi	0.82	23.2	37.34	2.4
5th		2.25	9.7	15.61	10.1
4th		4.67	4.8	7.88	23.5
3rd	Forward & Reverse 4WD/Low	2.4	9.1	14.64	10.9
2nd		6.54	3.5	5.63	34.8
1st		13.6	1.7	2.74	99.5

Based on a gross vehicle weight of 88,000 lb (39,916kg).

Crane operating angle must not exceed 35° (77% grade).

■ Fuel Tank

One 75 gallon (283.9L) capacity tank

■ Hydraulic System

All functions are hydraulically powered allowing positive precise control with independent or simultaneous operation of all functions.

Main Pumps

- One two section fixed displacement gear pump for the front/rear winches and boom hoist circuits.
- One two section fixed displacement gear pump for the swing/telescope, power steering/outrigger/telescope, service brake, and oscillation circuits.
- Combined pump capacity of 138 gpm (522.4Lpm)

Hydraulic Reservoir – 153 gal (579.2L) capacity equipped with sight level gauge. Diffusers built in for deaeration.

Filtration – One 10 micron, full flow line filter in the control circuit. All oil is filtered prior to return to reservoir. Accessible for easy filter replacement.

■ Pump Drive

All pumps are mounted on the transmission and mechanically driven by the diesel engine.

- Front/rear winches and boom hoist pumps can be disconnected with a manual pump disconnect to aid in cold weather starting – optional.

Axle Loads

Base crane with full tank of fuel	Gross Vehicle Weight ⁽¹⁾		Upper Facing Front				Upper Facing Rear			
			Front Axles		Rear Axles		Front Axles		Rear Axles	
	lb	kg	lb	kg	lb	kg	lb	kg	lb	kg
	83,952	38 080	39,888	18 093	44,064	19 987	35,690	16 189	48,262	21 891
Pintle hook, front	13	6	16	7	-4	-2	16	7	-4	-2
Pintle hook, rear	13	6	-5	-2	17	8	-5	-2	17	8
Rear steer indicator	6	3	0	0	6	3	0	0	6	3
Hydro-gas suspension	48	22	17	8	31	14	17	8	31	14
Pump disconnect	39	18	7	3	32	15	7	3	32	15
Operator in cab	250	113	134	61	116	53	103	47	147	67
Hoist drum follower – main	67	30	-28	-13	95	43	92	42	-25	-11
Auxiliary winch with 500 ft (152.4m) wire rope	538	244	-100	-45	638	289	610	277	-72	-33
Hoist drum follower – auxiliary	67	30	-17	-8	84	38	80	36	-13	-6
Substitute type “DB” rope with type “RB” rope – main winch	126	57	-44	-20	170	77	164	74	-38	-17
Substitute type “DB” rope with type “RB” rope – auxiliary winch	105	48	-19	-9	124	56	119	54	-14	-6
Substitute 500 ft (152.4m) wire rope with 600 ft (182.9m) – auxiliary	104	47	-19	-9	123	56	118	54	-14	-6
Remove 600 ft (182.9m) wire rope from rear (main) winch	-642	-291	226	103	-868	-394	-835	-377	193	88
Remove 500 ft (152.4m) wire rope from front (auxiliary) winch	-538	-244	100	45	-638	-289	-610	-277	72	33
Emergency steering	260	118	35	16	225	102	212	96	48	22
360° mechanical swing lock	140	64	52	24	88	40	81	37	59	27
Air conditioning	220	100	57	26	163	74	152	69	68	31
Floodlight to front of boom base section	7	3	13	6	-6	-3	-6	-3	13	6
Fly mounting brackets to boom base section for fly options	176	80	316	143	-140	-63	-149	-67	325	147
35 ft (10.67m) offsettable fly – stowed	1,591	722	2,504	1 136	-913	-414	-995	-451	2,586	1 173
35–58 ft (10.67–17.68m) offsettable fly – stowed	2,263	1 026	3,162	1 434	-899	-408	-1,016	-461	3,279	1 487
Auxiliary lifting sheave	110	50	297	135	-187	-85	-193	-88	303	137
60 ton (54.4mt) 4–sheave hook block at bumper	1,109	503	1,635	742	-526	-239	-583	-264	1,692	767
70 ton (63.5mt) 5–sheave hook block at bumper	1,400	635	2,064	936	-664	-301	-736	-334	2,136	969
8.5 ton (7.7mt) hook ball at bumper	360	163	531	241	-171	-78	-189	-86	549	249
60 ton (54.4mt) 4–sheave hook block at boom head	1,109	503	2,883	1 308	-1,774	-805	-1,831	-831	2,940	1 334
70 ton (63.5mt) 5–sheave hook block at boom head	1,400	635	3,640	1 651	-2,240	-1 016	-2,312	-1 049	3,712	1 684
8.5 ton (7.7mt) hook ball at boom head	360	163	936	425	-576	-261	-595	-670	955	433

Tire	Maximum Allowable Axle Load @ 25 mph (40.2km/h)
26.5 x 25 (26–PR)	51,040 lb (23 151kg)

⁽¹⁾ Adjust gross vehicle weight and axle loading according to component weight.

Note: All weights are ±3%.

General Dimensions

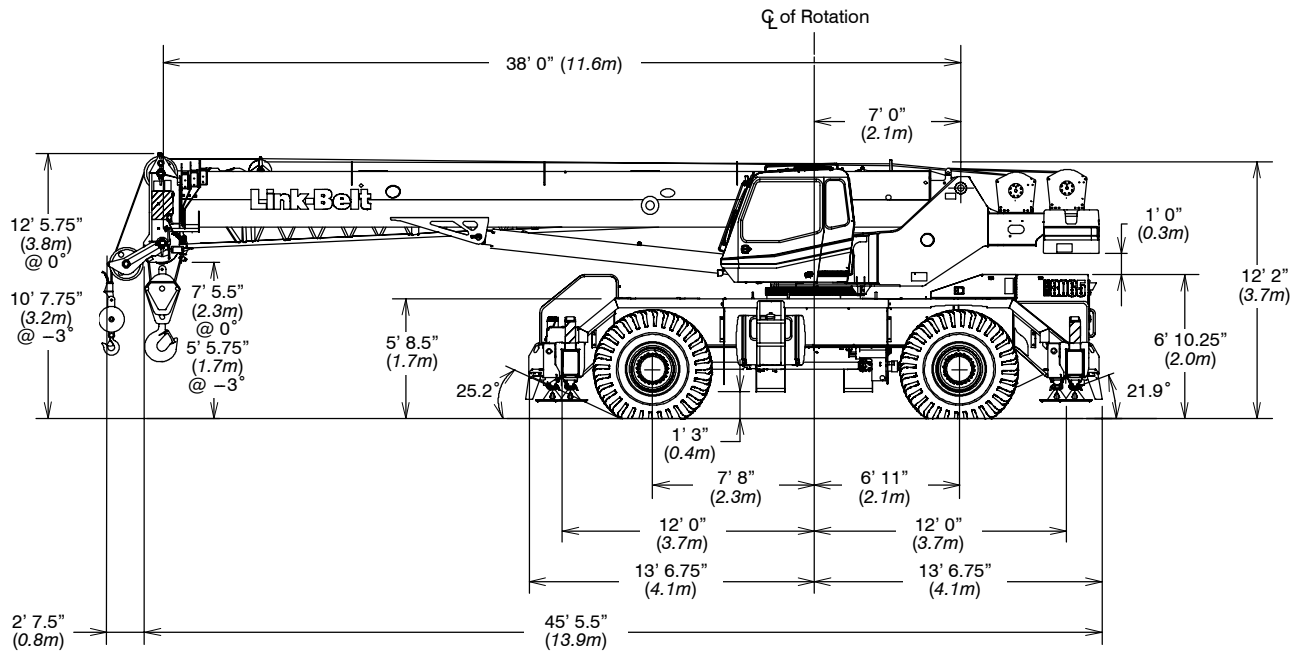

Turning Radius – Front Wheel (4x2) Steering		English	Metric
Wall to wall over carrier		43' 2"	13.2m
Wall to wall over boom attachment		53' 4"	16.3m
Curb to curb		41' 6"	12.6m
Centerline of tire		40' 1"	12.2m

Turning Radius – All Wheel (4x4) Steering		English	Metric
Wall to wall over carrier		26' 6"	8.1m
Wall to wall over boom attachment		38' 1"	11.6m
Curb to curb		24' 10"	7.6m
Centerline of tire		23' 6"	7.2m

Tail Swing		English	Metric
With counterweight		13' 8.25"	4.2m
Without counterweight		N/A	N/A

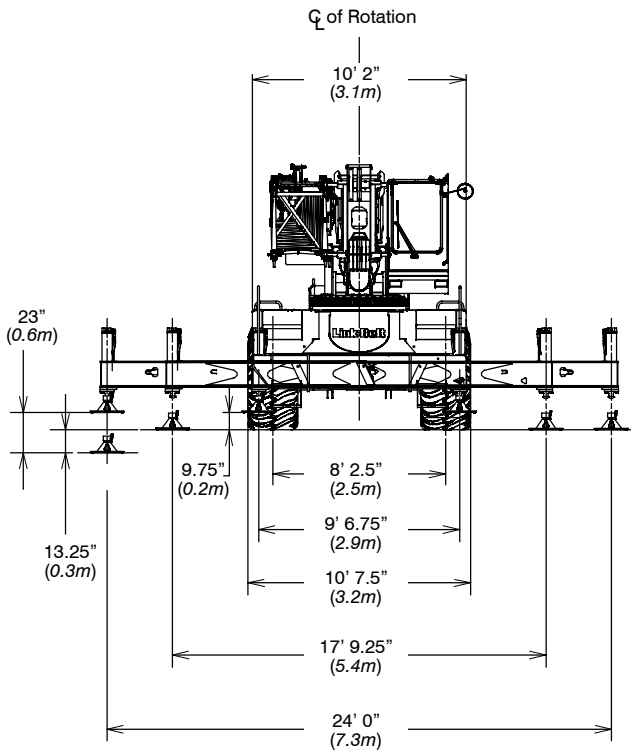

Not To Scale

Working Range Diagram

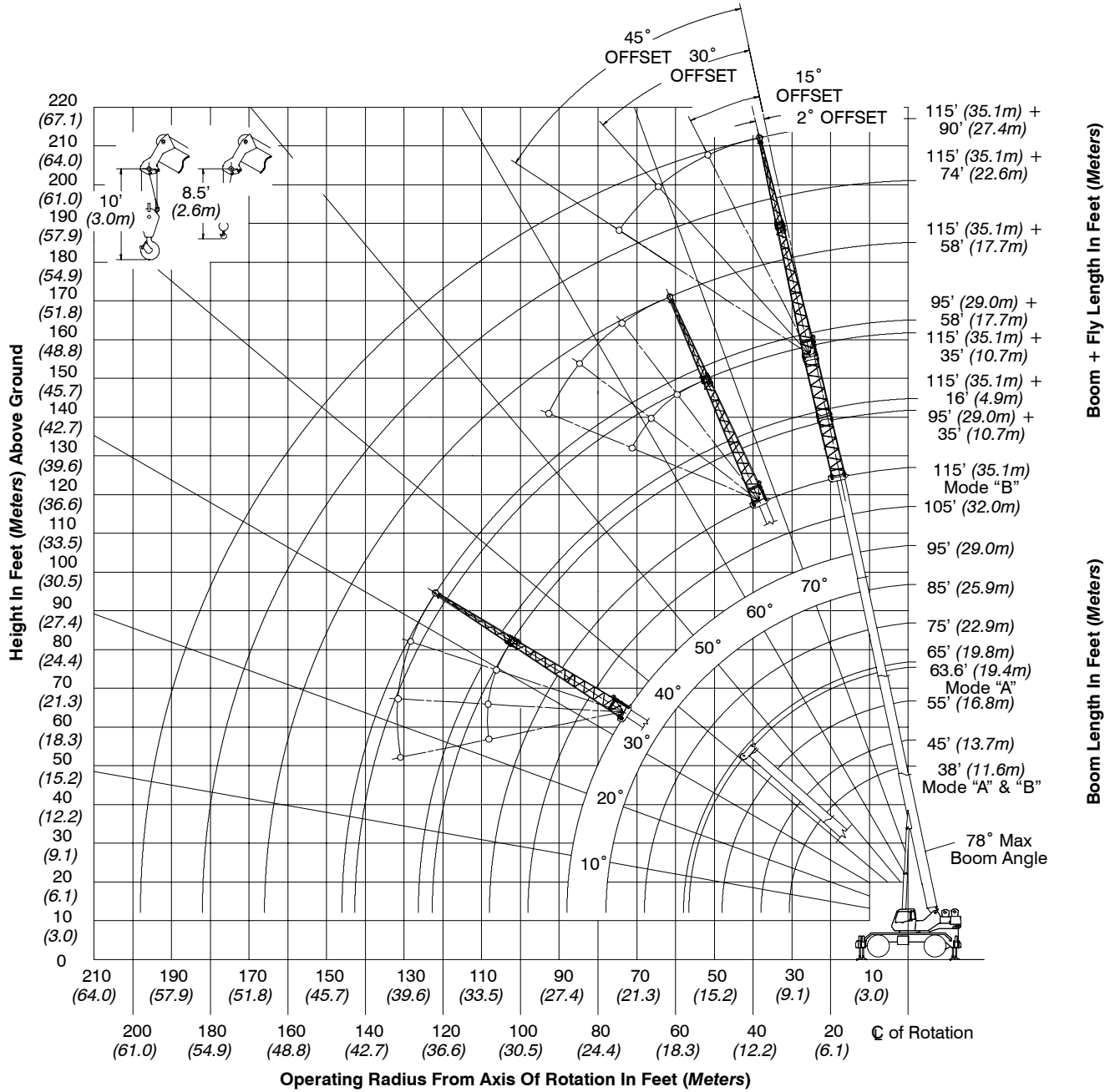

Boom Extend Modes

Boom Mode “A” (A-max)

Only inner mid section telescopes.

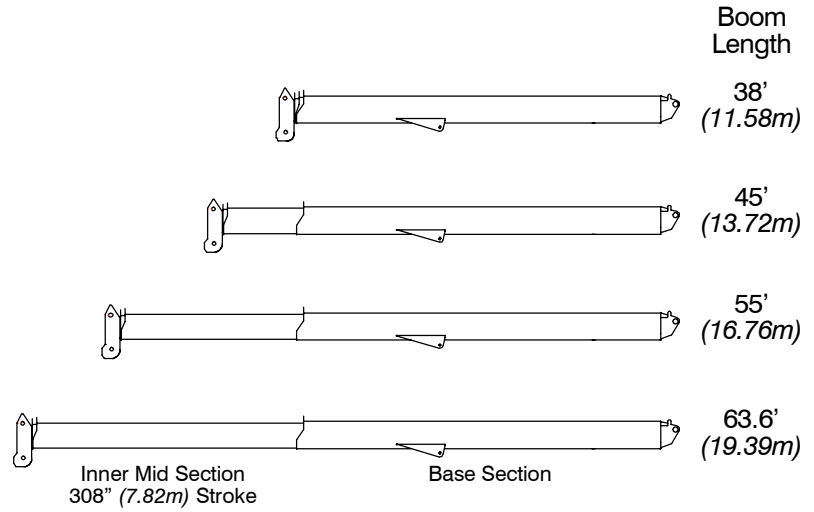

Boom Mode “B” (Standard)

Inner mid, outer mid, and tip sections telescope simultaneously.

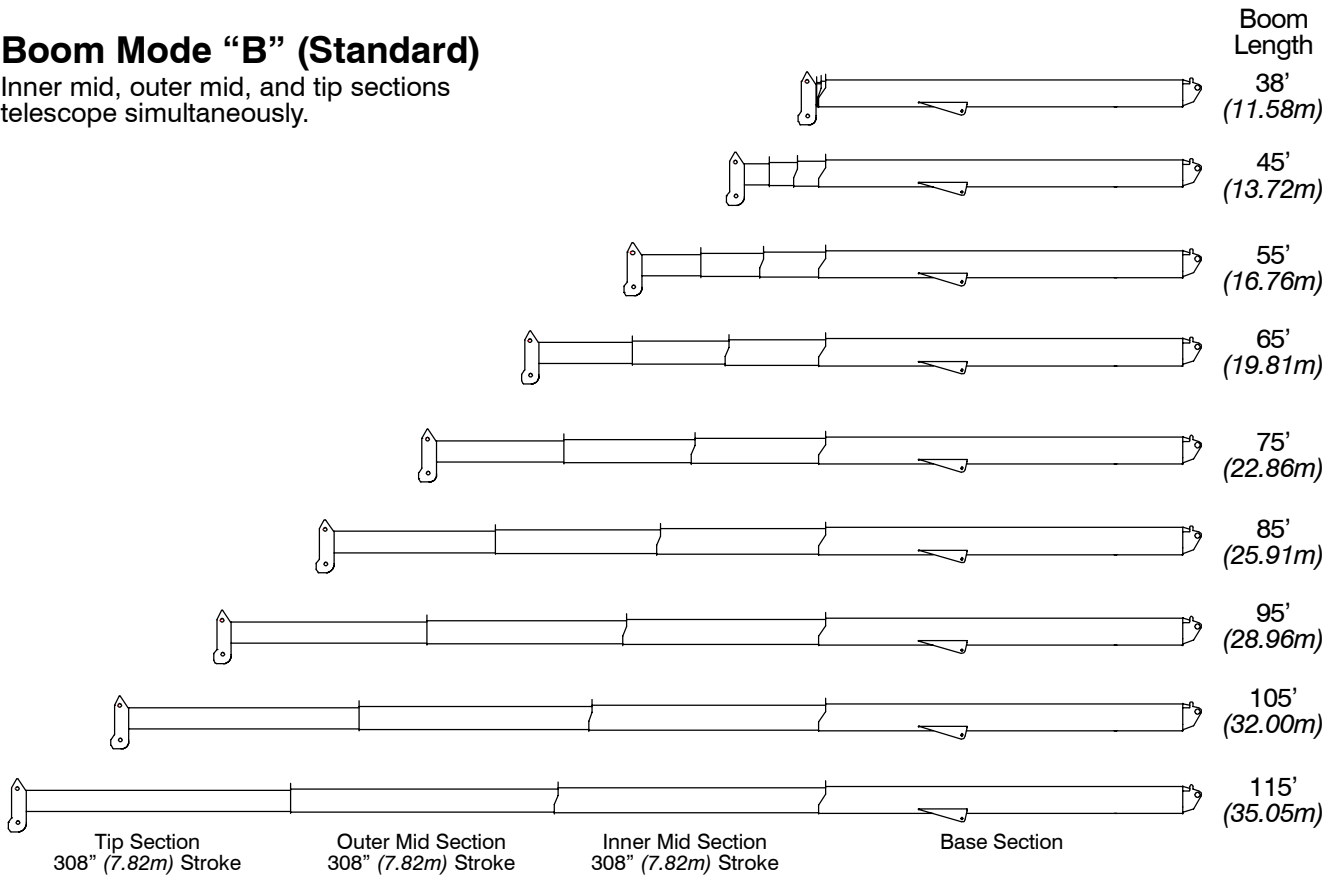

Main Boom Lift Capacity Charts – Standard

Fully Extended Outriggers – 360° Rotation (All Capacities Are Listed In Pounds)										
Radius (ft)	Boom Length (ft)									Radius (ft)
	38	45	55	63.6/65	75	85	95	105	115	
9	130,000									9
10	120,000	108,200	106,100							10
12	108,900	104,600	98,100	71,900**						12
15	91,600	91,200	86,200	71,900**	54,000					15
20	67,100	66,800	66,400	66,100**	54,000	55,900	46,400			20
25	52,000	52,600	53,000	53,000	53,700	49,900	41,800	36,200	28,100	25
30	41,800	42,500	43,000	43,400	43,600	43,800	37,800	34,200	28,100	30
35		33,300	33,900	34,200	34,400	34,600	34,000	30,700	28,100	35
40			26,400	26,700	26,900	27,100	27,200	27,300	25,700	40
45			21,200	21,600	21,800	22,000	22,100	22,100	22,200	45
50				17,700	18,000	18,100	18,200	18,300	18,300	50
55				14,800	15,000	15,100	15,200	15,300	15,400	55
60					12,700	12,800	12,900	13,000	13,000	60
65					10,800	11,000	11,100	11,200	11,200	65
70						9,400	9,500	9,600	9,700	70
75						8,100	8,200	8,300	8,300	75
80							7,100	7,100	7,200	80
85							6,100	6,200	6,200	85
90								5,300	5,400	90
95								4,600	4,600	95
100									4,000	100
105									3,400	105

** 63.6 A –max Mode

This information is not for crane operation. Operator must refer to the in-cab information for crane operation. Rated lifting capacities shown on fully extended outriggers do not exceed 85% of the tipping loads and on tires do not exceed 75% of the tipping loads.

On Tires – Stationary – Boom Centered Over Front Between Tire Tracks (All Capacities Are Listed In Pounds)							
Radius (ft)	Boom Length (ft)						Radius (ft)
	38	45	55	65	75	85	
10	64,000						10
12	56,800	56,400					12
15	48,500	48,900	39,500				15
20	38,400	39,100	39,500	30,400			20
25	29,000	29,700	30,100	30,400	22,400		25
30	20,600	21,400	21,900	22,200	22,400	17,200	30
35		16,000	16,600	16,900	17,100	17,200	35
40			12,900	13,300	13,400	13,600	40
45			10,200	10,600	10,800	11,000	45
50				8,500	8,800	8,900	50
55				6,800	7,100	7,300	55
60					5,700	5,900	60
65					4,600	4,800	65
70						3,900	70
75						3,100	75

This information is not for crane operation. Operator must refer to the in-cab information for crane operation. Rated lifting capacities shown on fully extended outriggers do not exceed 85% of the tipping loads and on tires do not exceed 75% of the tipping loads.

On Tires – Pick & Carry (Creep) – Boom Centered Over Front
(All Capacities Are Listed In Pounds)

Radius (ft)	Boom Length (ft)						Radius (ft)
	38	45	55	65	75	85	
10	63,000						10
12	55,200	54,900					12
15	46,300	46,700	39,500				15
20	35,700	36,100	36,600	30,400			20
25	28,300	28,800	29,300	29,600	22,400		25
30	20,600	21,400	21,900	22,200	22,400	17,200	30
35		16,000	16,600	16,900	17,100	17,200	35
40			12,900	13,300	13,400	13,600	40
45			10,200	10,600	10,800	11,000	45
50				8,500	8,800	8,900	50
55				6,800	7,100	7,300	55
60					5,700	5,900	60
65					4,600	4,800	65
70						3,900	70
75						3,100	75

On Tires – Stationary – 360° Rotation
(All Capacities Are Listed In Pounds)

Radius (ft)	Boom Length (ft)						Radius (ft)
	38	45	55	65	75	85	
10	47,700						10
12	39,000	39,500					12
15	26,800	27,400	27,800				15
20	16,200	16,800	17,300	17,600			20
25	10,500	11,100	11,700	12,000	12,200		25
30	6,800	7,500	8,100	8,400	8,600	8,800	30
35		5,000	5,600	5,900	6,200	6,300	35
40			3,800	4,100	4,400	4,600	40
45			2,400	2,800	3,000	3,200	45
50				1,700	1,900	2,100	50
55					1,100	1,200	55

This information is not for crane operation. Operator must refer to the in-cab information for crane operation. Rated lifting capacities shown on fully extended outriggers do not exceed 85% of the tipping loads and on tires do not exceed 75% of the tipping loads.

Fly Attachment Lift Capacity Charts – Optional

Fully Extended Outriggers – 360° Rotation (All Capacities Are Listed In Pounds)									
115 ft Main Boom Length 2° Fly Offset					115 ft Main Boom Length 15° Fly Offset				
Radius (ft)	Fly Length (ft)				Radius (ft)	Fly Length (ft)			
	35	58	74	90		35	58	74	90
35	13,100				35				
40	13,100				40				
45	13,100	8,800			45	11,800			
50	12,900	8,700	7,200		50	11,500			
55	12,600	8,400	7,200	5,500	55	11,200			
60	12,300	8,200	7,200	5,500	60	11,000	7,100		
65	12,000	8,000	7,000	5,400	65	10,700	6,900	5,900	
70	10,600	7,700	6,500	5,000	70	10,400	6,700	5,600	4,500
75	9,200	7,500	6,100	4,700	75	9,800	6,500	5,300	4,200
80	8,000	7,200	5,800	4,300	80	8,600	6,300	5,000	3,900
85	7,000	7,000	5,400	4,100	85	7,500	6,100	4,700	3,600
90	6,200	6,700	5,100	3,800	90	6,600	5,900	4,500	3,400
95	5,400	5,900	4,900	3,600	95	5,800	5,700	4,300	3,200
100	4,700	5,200	4,600	3,300	100	5,100	5,600	4,100	3,000
105	4,100	4,600	4,400	3,100	105	4,400	5,200	3,900	2,800
110	3,600	4,100	4,000	2,900	110	3,900	4,600	3,700	2,700
115	3,100	3,600	3,500	2,800	115	3,300	4,000	3,500	2,500
120	2,600	3,100	3,000	2,600	120	2,900	3,500	3,400	2,400
125	2,200	2,700	2,600	2,500	125	2,400	3,100	3,000	2,200
130	1,900	2,300	2,200	2,200	130	2,000	2,700	2,600	2,100
135	1,500	2,000	1,900	1,900	135	1,600	2,300	2,200	2,000
140	1,200	1,600	1,500	1,500	140	1,300	1,900	1,800	1,900
145		1,400	1,200	1,200	145		1,600	1,500	1,500
150		1,100	1,000		150		1,300	1,200	1,200
155		800			155		1,000	900	900

This information is not for crane operation. Operator must refer to the in-cab information for crane operation. Rated lifting capacities shown on fully extended outriggers do not exceed 85% of the tipping loads and on tires do not exceed 75% of the tipping loads.

Fully Extended Outriggers – 360° Rotation (All Capacities Are Listed In Pounds)									
115 ft Main Boom Length 30° Fly Offset					115 ft Main Boom Length 45° Fly Offset				
Radius (ft)	Fly Length (ft)				Radius (ft)	Fly Length (ft)			
	35	58	74	90		35	58	74	90
40					40				
45					45				
50					50				
55	9,900				55				
60	9,700				60	8,900			
65	9,500				65	8,800			
70	9,400				70	8,700			
75	9,200	5,600			75	8,600			
80	9,100	5,500	4,200		80	8,600			
85	8,000	5,300	4,000	3,200	85	8,400	4,900		
90	7,000	5,200	3,800	3,000	90	7,300	4,800	3,400	
95	6,200	5,100	3,700	2,900	95	6,400	4,700	3,300	2,600
100	5,400	5,000	3,500	2,700	100	5,600	4,700	3,200	2,500
105	4,700	4,900	3,400	2,500	105	4,900	4,700	3,100	2,300
110	4,100	4,900	3,200	2,400	110	4,200	4,600	3,000	2,200
115	3,500	4,500	3,100	2,300	115	3,600	4,600	2,900	2,100
120	3,000	3,900	3,000	2,100	120		4,200	2,800	2,000
125	2,500	3,400	2,900	2,000	125		3,700	2,700	1,900
130	2,100	3,000	2,800	1,900	130		3,200	2,700	1,800
135		2,500	2,500	1,800	135		2,700	2,600	1,700
140		2,200	2,200	1,700	140		2,200	2,300	1,600
145		1,800	1,800	1,600	145			1,900	1,600
150		1,400	1,400	1,500	150			1,600	1,500
155		1,100	1,100	1,200	155				1,400
160			800	900	160				1,000

This information is not for crane operation. Operator must refer to the in-cab information for crane operation. Rated lifting capacities shown on fully extended outriggers do not exceed 85% of the tipping loads and on tires do not exceed 75% of the tipping loads.

Main Boom Lift Capacity Charts – Metric

Fully Extended Outriggers – 360° Rotation (All Capacities Are Listed In Kilograms)										
Radius (m)	Boom Length (m)								Radius (m)	
	11.58	13.7	16.8	19.39/19.8	22.9	25.9	29.0	32.0		35.05
2.5	60 000									2.5
3	54 800	49 000	48 100							3
3.5	50 650	48 650	45 550	32 600**						3.5
4	46 900	45 250	42 300	32 600**						4
4.5	42 250	42 050	39 500	32 600**	24 450					4.5
5	37 800	37 600	37 100	32 600**	24 450					5
6	31 000	30 850	30 650	30 500**	24 450	25 550	21 150			6
7	26 050	25 900	25 750	25 650**	24 450	23 700	19 750			7
8	22 300	22 600	22 850	23 000	23 100	22 050	18 500	16 400	12 800	8
9	18 200	18 500	18 700	18 850	18 950	19 050	17 300	15 650	12 800	9
10		15 050	15 300	15 450	15 550	15 600	15 650	14 550	12 800	10
12			10 900	11 050	11 100	11 200	11 250	11 250	11 300	12
14			8 150	8 300	8 400	8 450	8 500	8 500	8 550	14
16				6 450	6 550	6 600	6 650	6 650	6 700	16
18					5 250	5 300	5 350	5 400	5 400	18
20					4 250	4 300	4 350	4 400	4 400	20
22						3 500	3 550	3 600	3 600	22
24							2 900	2 950	3 000	24
26							2 400	2 450	2 450	26
28								2 000	2 050	28
30									1 650	30
32									1 350	32

** 19.39 A – max Mode

This information is not for crane operation. Operator must refer to the in-cab information for crane operation. Rated lifting capacities shown on fully extended outriggers do not exceed 75% of the tipping loads and on tires do not exceed 65% of the tipping loads.

On Tires – Stationary – Boom Centered Over Front Between Tire Tracks (All Capacities Are Listed In Kilograms)							
Radius (m)	Boom Length (m)						Radius (m)
	11.58	13.7	16.8	19.8	22.9	25.9	
3	29 000						3
3.5	26 500						3.5
4	24 200	24 050					4
4.5	22 250	22 450	17 900				4.5
5	20 550	20 750	17 900				5
6	17 700	17 950	17 900	13 750			6
7	13 350	13 600	13 750	13 750			7
8	10 400	10 700	10 900	11 000	10 150		8
9	8 350	8 650	8 850	8 950	9 000	7 800	9
10		7 100	7 350	7 450	7 500	7 550	10
12			5 250	5 400	5 450	5 500	12
14			3 800	4 000	4 100	4 150	14
16				3 000	3 100	3 150	16
18					2 350	2 400	18
20					1 750	1 850	20
22						1 400	22

This information is not for crane operation. Operator must refer to the in-cab information for crane operation. Rated lifting capacities shown on fully extended outriggers do not exceed 75% of the tipping loads and on tires do not exceed 65% of the tipping loads.

On Tires – Pick & Carry (Creep) – Boom Centered Over Front
(All Capacities Are Listed In Kilograms)

Radius (m)	Boom Length (m)						Radius (m)
	11.58	13.7	16.8	19.8	22.9	25.9	
3	28 550						3
3.5	25 900						3.5
4	23 400	23 550					4
4.5	21 250	21 450	17 900				4.5
5	19 400	19 600	17 900				5
6	16 400	16 650	16 850	13 750			6
7	13 350	13 600	13 750	13 750			7
8	10 400	10 700	10 900	11 000	10 150		8
9	8 350	8 650	8 850	8 950	9 000	7 800	9
10		7 100	7 350	7 450	7 500	7 550	10
12			5 250	5 400	5 450	5 500	12
14			3 800	4 000	4 100	4 150	14
16				3 000	3 100	3 150	16
18					2 350	2 400	18
20					1 750	1 850	20
22						1 400	22

On Tires – Stationary – 360° Rotation
(All Capacities Are Listed In Kilograms)

Radius (m)	Boom Length (m)						Radius (m)
	11.58	13.7	16.8	19.8	22.9	25.9	
3	21 550						3
3.5	16 500						3.5
4	13 200	13 400					4
4.5	10 850	11 050	11 200				4.5
5	9 050	9 300	9 450				5
6	6 550	6 800	7 000	7 100			6
7	4 900	5 150	5 350	5 450			7
8	3 700	3 950	4 150	4 300	4 350		8
9	2 800	3 050	3 250	3 400	3 500	3 550	9
10		2 350	2 550	2 700	2 800	2 850	10
12			1 550	1 700	1 800	1 850	12
14			850	1 000	1 100	1 150	14
16				450	550	650	16

This information is not for crane operation. Operator must refer to the in-cab information for crane operation. Rated lifting capacities shown on fully extended outriggers do not exceed 75% of the tipping loads and on tires do not exceed 65% of the tipping loads.

Fly Attachment Lift Capacity Charts – Optional

Fully Extended Outriggers – 360° Rotation (All Capacities Are Listed In Kilograms)									
35.05 m Main Boom Length 2° Fly Offset					35.05 m Main Boom Length 15° Fly Offset				
Radius (m)	Fly Length (m)				Radius (m)	Fly Length (m)			
	10.67	17.68	22.56	27.43		10.67	17.68	22.56	27.43
12	5 900				12				
14	5 900	4 000			14	5 350			
16	5 750	3 850	3 250		16	5 150			
18	5 600	3 750	3 250	2 500	18	5 000			
20	4 750	3 600	3 150	2 400	20	4 850	3 100	2 650	
22	3 950	3 450	2 900	2 200	22	4 200	3 000	2 450	1 950
24	3 300	3 300	2 650	2 000	24	3 550	2 850	2 300	1 800
26	2 800	3 000	2 450	1 850	26	2 950	2 750	2 150	1 650
28	2 350	2 550	2 300	1 700	28	2 500	2 650	2 000	1 500
30	1 950	2 150	2 100	1 550	30	2 100	2 400	1 850	1 400
32	1 650	1 850	1 800	1 400	32	1 750	2 050	1 750	1 300
34	1 350	1 550	1 500	1 300	34	1 450	1 750	1 650	1 200
36	1 100	1 300	1 250	1 200	36	1 200	1 450	1 450	1 100
38	900	1 050	1 050	1 050	38	950	1 250	1 200	1 000
40	700	900	850	850	40	750	1 000	950	950
42	550	700	650	650	42	550	800	800	800
44		550	500	500	44		650	600	600
46		400			46		500	450	450
48					48		350		

This information is not for crane operation. Operator must refer to the in-cab information for crane operation. Rated lifting capacities shown on fully extended outriggers do not exceed 75% of the tipping loads and on tires do not exceed 65% of the tipping loads.

Fully Extended Outriggers – 360° Rotation (All Capacities Are Listed In Kilograms)									
35.05 m Main Boom Length 30° Fly Offset					35.05 m Main Boom Length 45° Fly Offset				
Radius (m)	Fly Length (m)				Radius (m)	Fly Length (m)			
	10.67	17.68	22.56	27.43		10.67	17.68	22.56	27.43
18	4 450				18				
20	4 300				20	4 000			
22	4 200				22	3 950			
24	3 750	2 500			24	3 900			
26	3 150	2 400	1 800	1 450	26	3 300	2 200		
28	2 650	2 350	1 700	1 350	28	2 800	2 150	1 550	
30	2 250	2 300	1 600	1 250	30	2 350	2 150	1 450	1 150
32	1 900	2 250	1 550	1 150	32	1 950	2 100	1 400	1 050
34	1 550	1 950	1 450	1 050	34	1 600	2 100	1 350	1 000
36	1 250	1 650	1 400	1 000	36		1 750	1 300	900
38	1 000	1 350	1 300	900	38		1 450	1 250	850
40	800	1 150	1 150	850	40		1 200	1 200	800
42		900	900	800	42		950	1 000	750
44		700	700	750	44			800	700
46		550	550	550	46			600	650
48			400	400	48				450

This information is not for crane operation. Operator must refer to the in-cab information for crane operation. Rated lifting capacities shown on fully extended outriggers do not exceed 75% of the tipping loads and on tires do not exceed 65% of the tipping loads.

Link-Belt Construction Equipment Company Lexington, Kentucky www.linkbelt.com

®Link-Belt is a registered trademark. Copyright 2006. We are constantly improving our products and therefore reserve the right to change designs and specifications.