

GMK5275

product guide

features

- 44 - 223 ft. (13.3 - 68 m) 7 section full power Mega Form boom with Twin Lock pinning
- 39 - 69 ft. (12 - 21 m) hydraulic offset bi-fold swingaway
- 2 x 26 ft. (8 m) intermediate lattice inserts
- 169,700 lb. (77 t) counterweight with hydraulic removal system
- MEGATRAK independent hydro-pneumatic suspension

contents

Features	2
Specifications	3
Dimensions	5
Travel Proposal	6
Specifications	7
Dimensions	9
Travel Proposal	10
Counterweight Dimensions	11
Working Range Main Boom	12
Load Charts	13
Working Range Hydraulic Offset Swingaway	16
Hydraulic Offset Swingaway Charts	18
Working Range Heavy Duty Jib	21
Load Chart Heavy Duty Jib	23



features

2



Cummins QSX15, chassis engine
535 bhp (399 kW) @ 2100 rpm 1873
ft./lb. torque (2539 Nm) @ 1400
rpm.

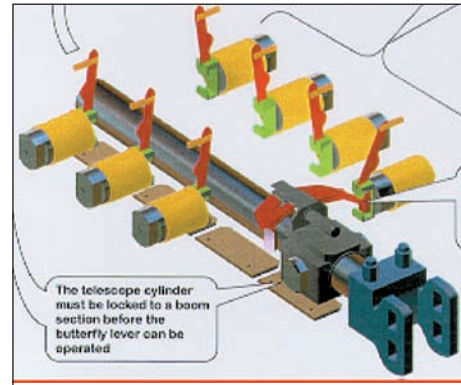

TWIN-LOCK™
Boom pinning mechanism
automatically pins the sections in
position using two horizontal large
diameter boom pins

LUFFING BI-FOLD SWINGAWAY
Hydraulically offset lattice bi-fold
swingaway lets the operator set the
offset from 5°-40° while under load,
from the superstructure cab

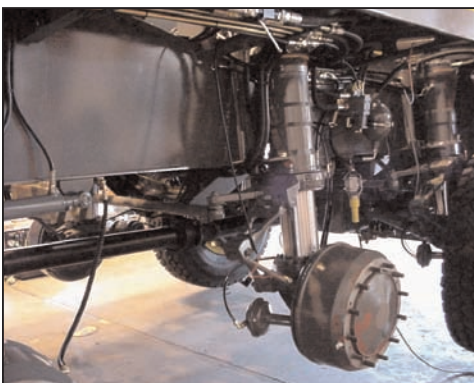
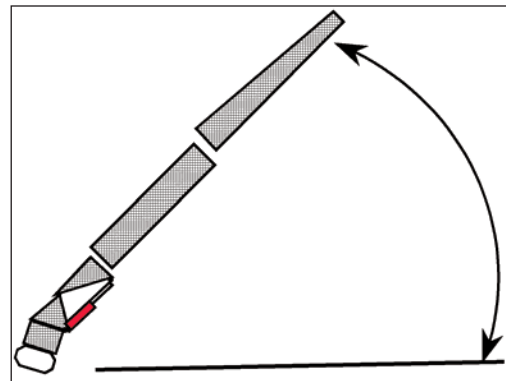

The exclusive Grove MEGATRAK™
independent suspension system allows all
wheels to be on the ground at all times; now
with top steering on rear axles.

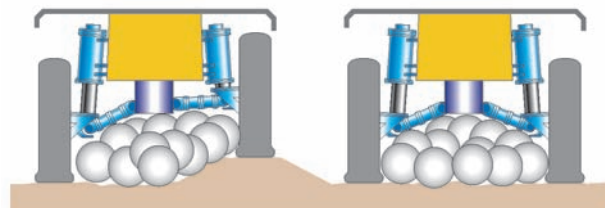

specifications

3

Superstructure – North American Version

Boom

44 ft. - 223 ft. (13.3 m - 68 m) 7 section, full power Mega Form boom with **Twin Lock Pinning**.
Maximum tip height: 233 ft. (71 m)

Boom Nose

Eight nylatron sheaves, mounted on heavy duty tapered roller bearings with removable pin-type rope guards. Quick reeve boom nose. Removable auxiliary boom nose with removable pin type rope guard.

Boom Elevation

Single lift cylinder with safety valve provides boom angle from -1.5° to +83°.

Hydraulic Offsettable Lattice Extension

39 ft. - 69 ft. (12 - 21 m) bi-fold lattice swingaway extension, hydraulically offsettable and luffing under load, 5°- 40°. Maximum tip height: 302 ft (92 m)

Lattice Inserts

2 x 26 ft. (8 m) inserts for use with lattice swingaway extension to increase length to 95 ft. (29 m) or 121 ft. (37 m)
Maximum tip height: 354 ft (107.7 m)

Load Moment & Anti-Two Block System

Load moment and anti-two block system with audio/visual warning and control lever lockout provides electronic display of boom angle, length, radius, tip height, relative load moment, maximum permissible load, load indication and warning of impending two-block condition.

Cab

All aluminum constructed cab with acoustical lining, hydraulic tilted to 20°. Includes tinted safety glass, adjustable operator's seat with hydraulic suspension, opening windows at side and rear, hinged windshield with wiper, sun visor and window shade. Other features include hot water heater/defroster, armrest integrated crane controls and ergonomically arranged instrumentation.

Swing

3 planetary gear boxes with fixed displacement axial piston motors. Infinitely variable to 1.3 rpm. Free swing or hydrostatically engaged brake controlled by swing lever. Swing brake selected by foot operated switch.

Counterweight

169,700 lbs. (77 t) consisting of various sections with hydraulic installation/removal system controlled from the superstructure cab.

Engine

Cummins QSB6.7, 6 cylinder
Horsepower: 220 bhp (164 kW) at 2200 rpm
Torque: 700 ft./lb. (949 Nm) at 1500 rpm
Off-road: EPA/CARB/EUROMOT (III)

Fuel Tank Capacity

61 gal. (230 l)

Electrical System

3 phase alternator: 28V/80A
2 batteries: 12V/170Ah

Hydraulic System

3 separate circuits, 1 axial piston variable displacement pump (load sensing) with electronic power limiting control for crane functions and 2 gear pumps for swing and outrigger functions. Thermostatically controlled oil coolers keep oil at optimum operating temperature.
Hydraulic tank capacity: 242 gal. (915 l)

Hoist

Main and auxiliary hoist are powered by axial piston motor with planetary gear and brake. "Thumb-thumper" hoist drum rotation indicator alerts operator of hoist movement.

	Main	Auxiliary
Rope length:	951 ft. (290 m)	951 ft. (290 m)
Rope diameter:	22 mm	22 mm
Line speed:	410 ft./min. (125 m/min)	410 ft./min. (125 m/min)
Line pull:	21,020 lbs. 93.5 kN)	21,020 lbs. (93.5 kN)

*Optional Equipment

- *Work lights, mounted on boom base section
- *Boom mounted aircraft warning light
- *Timer for diesel heater
- *Radio/CD player for superstructure cab
- *Stainless steel exhaust system with spark arrestor
- *Air conditioning
- *Hook blocks/headache ball
- *Engine independent diesel cab heater, with engine pre-heater
- *Additional cab mounted work light
- *Strobe light
- *Working range limiter
- *Data logger

*Denotes optional equipment

GMK5275

GROVE

specifications

4

Carrier – North American Version

Chassis

Box type, torsion resistant frame is fabricated from high strength steel.

Outrigger System

Four hydraulic two stage outrigger beams with vertical cylinders and outrigger pads, 23.6" (600 mm) square . Outrigger can be set in 5 positions:

Full	- 26.6' (8.1 m)
Partial	- 22.4' (6.8 m)
Partial	- 18.4' (5.6 m)
Partial	- 14.4' (4.4 m)
Retracted	- 9.0' (2.7 m)

Independent horizontal and vertical movement controlled from each side of carrier and the superstructure cab. Electronic crane level indicators.

Transmission

Allison 6 speeds forward, 1 reverse
2 speed transfer case

Drive/Steer

10x8x10

Axles

1st axle line – steer
2nd axle line – steer/(optional drive)
3rd axle line – drive/steer (permanent drive with 10x6, disconnects for highway with 10x8)
4th axle line – drive/steer (connects for all wheel steer)
5th axle line – drive/steer
Drive axles with planetary hub reduction and center mounted gearing. Standard inter-axle and cross axle differential locks.

Suspension

Grove exclusive MEGATRAK suspension. Independent hydro-pneumatic system acting on all wheels with hydraulic lockout. Suspension can be raised 6.3" (160 mm) or lowered 4.7" (120 mm), both longitudinally and transversely. Features an automatic leveling system for highway travel.

Tires

10 tires, 16.00R25 (Vehicle width – 10.2' [3.1 m])

Steering

Dual circuit, hydraulic power assisted steering system. Transfer case mounted, ground driven emergency steering pump. Axles 1, 2, 3 and 5 steer on highway. Separate steering of the 4th and 5th axles for all wheel and crab steering, controlled by an electronic rocker switch.

Engine

Cummins QSX15, 6 cylinder
Horsepower: 535 bhp (399 kW) at 2100 rpm
Torque: 1873 ft./lb. (2539 Nm) at 1400 rpm
Off-road: EPA /CARB/EUROMOT (III)
Standard compression brake, disconnected when hydraulic transmission retarder is optioned

Fuel Tank Capacity

105 gallons (397 L).

Electrical System

3 phase alternator: 28V/80A
2 batteries: 12V/170Ah

Brakes

Service brakes: pneumatic dual circuit acting on all wheels.
Parking brake: pneumatically operated spring loaded brake acting on axle lines 2, 3, 4 and 5.
Air dryer.

Cab

Two-man, aluminum construction with the following features: safety glass, driver and passenger seats with hydraulic suspension, engine-dependent hot water heater, power windows, heated rear view mirrors, complete instrumentation and driving controls.

Electrical System

24V system with three phase alternator, 28V/100A
2 batteries, 12V/170 Ah

Maximum Speed

53 mph (85 kph)

Gradeability (Theoretical)

50% - 14.00 tires
45% - 16.00/20.5 tires

Miscellaneous Standard Equipment

Work light; tool kit; fire extinguishers; auxiliary boom nose; radio/CD player in carrier cab, heated rear view mirrors, wind speed indicator.

*Optional Equipment

- *Timer for diesel heater
- *Stainless steel exhaust system with spark arrestor
- *Air conditioning
- *14.00R25 tires (vehicle width 9.8 ft.[3.0 m])
- *20.5R25 tires (vehicle width 10.2 ft.[3.1 m])
- *10x6x10 drive/steer
- *Transmission retarder (in lieu of engine compression brake)
- *Engine independent diesel cab heater, with engine pre-heater
- *Strobe light
- *Work lights for outriggers
- *Spare tire and wheel with carry bracket
- *Aluminum edging for decking
- *Rear mounted stowage box
- *Outrigger pad load indicator
- *Trailer hitch
- *Steel outrigger pads

*Denotes optional equipment

GMK5275

GROVE

dimensions

Weights & Dimensions – North American Version

5

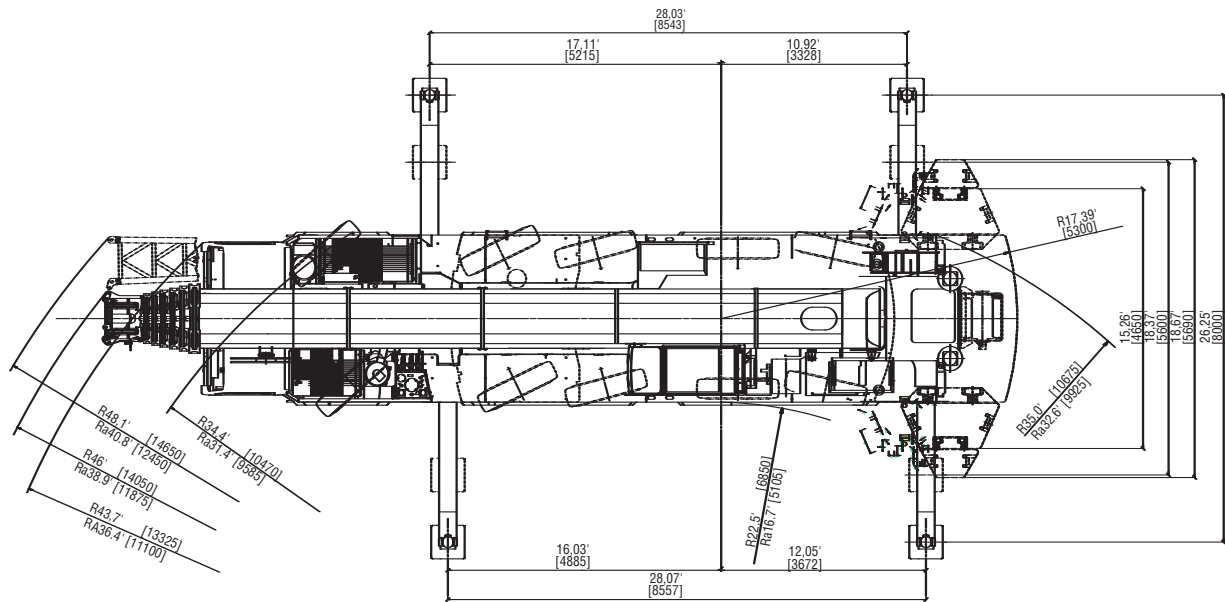
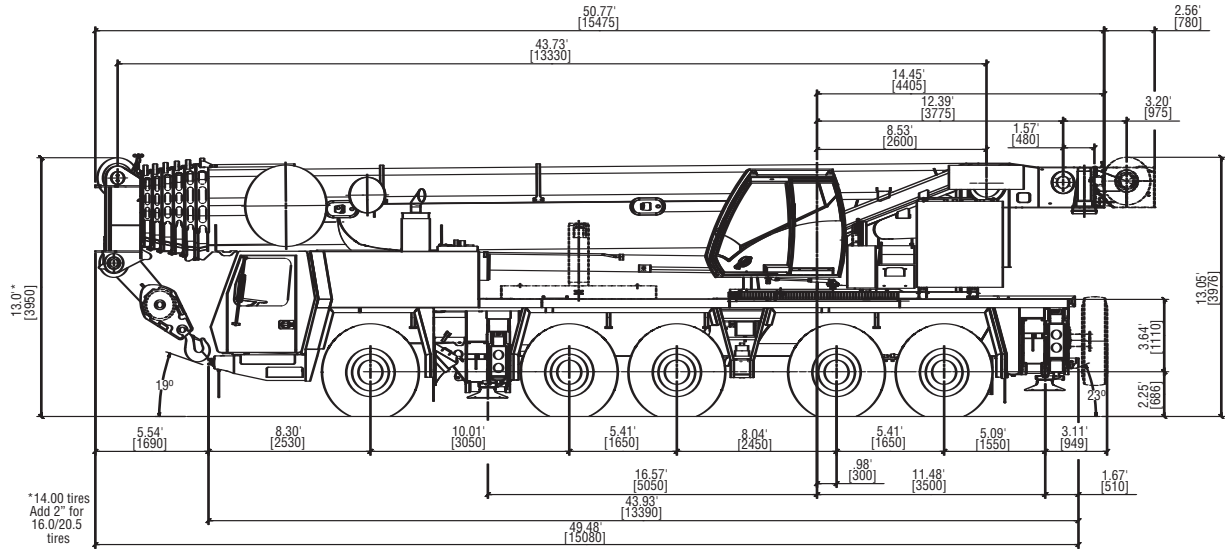

Basic Weights - lb. (kg.)	Axles 1-3		Axles 4 & 5		Total
Cummins power, 14.00 tires, 10X6X10 drive/steer and driver.	82,561	(37449)	48,249	(21886)	130,810 (59335)
Additions:					
10X8X10 drive/steer	703	(319)	79	(36)	783 (355)
14.00R25 spare tire with bracket	-280	(-127)	864	(392)	584 (265)
16.00R25 spare tire with bracket	-342	(-155)	1,058	(480)	717 (325)
20.5R25 spare tire with bracket	-386	(-175)	1,195	(542)	809 (367)
Brackets and hose reel for swingaway	922	(418)	-326	(-148)	595 (270)
39 ft. - 69 ft. (12 m - 21 m) swingaway	5,060	(2295)	-628	(-285)	4,431 (2010)
Auxiliary hoist	-2,544	(-1154)	6,380	(2894)	3,836 (1740)
Substitutions					
16.00R25 tires	794	(360)	529	(240)	1,323 (600)
20.5R25 tires	1,349	(612)	900	(408)	2,249 (1020)
Remove:					
Boom assembly	-43,641	(-19795)	-2,998	(-1360)	-46,639 (-21155)
Front outriggers	-4,773	(-2165)	606	(275)	-4,167 (-1890)
Rear outriggers	2,273	(1031)	-7,432	(-3371)	-5,159 (-2340)
Front and rear outrigger floats	-157	(-71)	-284	(-129)	-441 (-200)

GMK5275

GROVE

trailing boom proposal

Trailing Boom Weights – North American Version

6

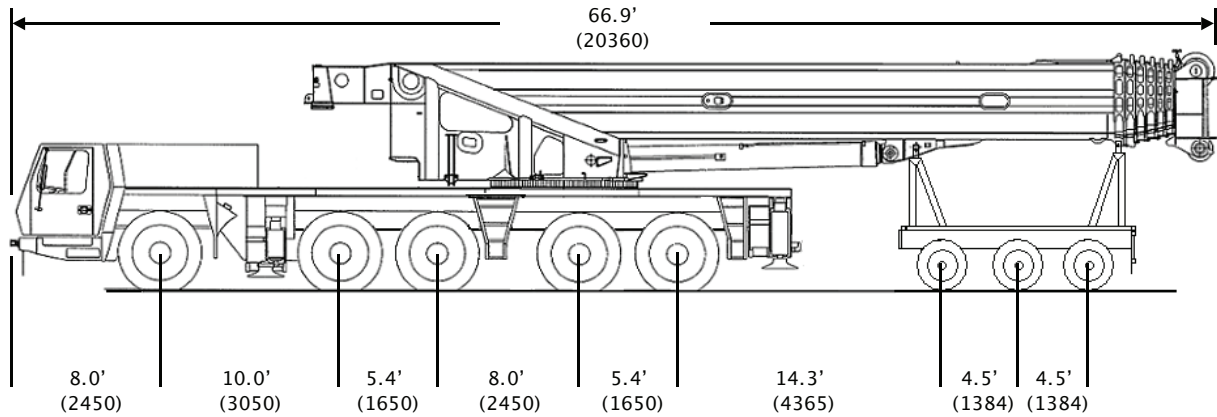

Basic Weights - lb. (kg.)	Axes 1-3		Axes 4 & 5		Dolly		Total	
Cummins power, 16.00 tires, 10X8X10 drive/steer, outrigger pads stowed, auxiliary hoist, 69 ft. swingaway stowed, additional oil cooler, 9500 lb. dolly.	67,515 (30625)		39,584 (17955)		44,265 (20078)		151,365 (68659)	
Substitutions								
14.00R25 tires	-794	(-360)	-529	(-240)	-	-	-1,323	(-600)
20.5R25 tires	556	(252)	370	(168)	-	-	926	(420)
10X6X10 drive/steer	-703	(-319)	-79	(-36)	-	-	-783	(-355)
Remove:								
39 ft. - 69 ft. (12 - 21 m) swingaway	-794	(-360)	-355	(-161)	-3,283	(-1489)	-4,431	(-2010)
Auxiliary hoist	-4,145	(-1880)	309	(140)	-	-	-3,836	(-1740)
Front outriggers	-4,773	(-2165)	606	(275)	-	-	-4,167	(-1890)
Rear outriggers	2,273	(1031)	-7,432	(-3371)	-	-	-5,159	(-2340)
Front and rear outrigger floats	-154	(-70)	-287	(-130)	-	-	-441	(-200)

GMK5275

GROVE

specifications

7

Superstructure – European Version

Boom

44 ft. - 223 ft. (13.3 m - 68 m) 7 section, full power Mega Form boom with **Twin Lock Pinning**.
Maximum tip height: 233 ft. (71 m)

Boom Nose

Eight nylatron sheaves, mounted on heavy duty tapered roller bearings with removable pin-type rope guards. Quick reeve boom nose. Removable auxiliary boom nose with removable pin type rope guard.

Boom Elevation

Single lift cylinder with safety valve provides boom angle from -1.5° to +83°.

Hydraulic Offsettable Lattice Extension

39 ft. – 69 ft. (12 - 21 m) bi-fold lattice swingaway extension, hydraulically offsettable and luffing under load, 5°- 40°. Maximum tip height: 302 ft (92 m)

Lattice Inserts

2 x 26 ft. (8 m) inserts for use with lattice swingaway extension to increase length to 95 ft. (29 m) or 121 ft. (37 m)
Maximum tip height: 354 ft (107.7 m)

Load Moment & Anti-Two Block System

Load moment and anti-two block system with audio/visual warning and control lever lockout provides electronic display of boom angle, length, radius, tip height, relative load moment, maximum permissible load, load indication and warning of impending two-block condition.

Cab

All aluminum constructed cab with acoustical lining, hydraulic tilted to 20°. Includes tinted safety glass, adjustable operator's seat with hydraulic suspension, opening windows at side and rear, hinged windshield with wiper, sun visor and window shade. Other features include diesel heater/defroster, armrest integrated crane controls and ergonomically arranged instrumentation.

Swing

3 planetary gear boxes with fixed displacement axial piston motors. Infinitely variable to 1.3 rpm. Free swing or hydrostatically engaged brake controlled by swing lever. Swing brake selected by foot operated switch.

Counterweight

169,700 lbs. (77 t) consisting of various sections with hydraulic installation/removal system controlled from the superstructure cab.

Engine

Mercedes OM 906 LA, 6 cylinder
Horsepower: 228 bhp (170 kW) at 2200 rpm
Torque: 597 ft./lb. (810 Nm) at 1200 rpm
Off-road: EPA/CARB/EUROMOR (III)

Fuel Tank Capacity

Supplied from chassis fuel tank.

Electrical System

3 phase alternator: 28V/80A
2 batteries: 12V/170Ah

Hydraulic System

3 separate circuits, 1 axial piston variable displacement pump (load sensing) with electronic power limiting control for crane functions and 2 gear pumps for swing and outrigger functions. Thermostatically controlled oil coolers keep oil at optimum operating temperature.
Hydraulic tank capacity: 242 gal. (915 l)

Hoist

Main and auxiliary hoist are powered by axial piston motor with planetary gear and brake. "Thumb-thumper" hoist drum rotation indicator alerts operator of hoist movement.

	Main	Auxiliary
Rope length:	951 ft. (290 m)	951 ft. (290 m)
Rope diameter:	22 mm	22 mm
Line speed:	410 ft./min. (125 m/min)	410 ft./min. (125 m/min)
Line pull:	21,020 lbs. (93.5 kN)	21,020 lbs. (93.5 kN)

*Optional Equipment

- *Work lights, mounted on boom base section
- *Boom mounted aircraft warning light
- *Timer for diesel heater
- *Radio/CD player for superstructure cab
- *Stainless steel exhaust system with spark arrestor
- *Air conditioning
- *Hook blocks/headache ball
- *Engine independent diesel cab heater, with engine pre-heater
- *Additional cab mounted work light
- *Strobe light
- *Working range limiter
- *Data logger

*Denotes optional equipment

GMK5275

GROVE

specifications

8

Carrier – European Version

Chassis

Box type, torsion resistant frame is fabricated from high strength steel.

Outrigger System

Four hydraulic two stage outrigger beams with vertical cylinders and outrigger pads, 23.6" (600 mm) square . Outrigger can be set in 5 positions:

Full	- 26.6' (8.1 m)
Partial	- 22.3' (6.8 m)
Partial	- 18.4' (5.6 m)
Partial	- 14.4' (4.4 m)
Retracted	- 9.0' (2.7 m)

Independent horizontal and vertical movement controlled from each side of carrier and the superstructure cab. Electronic crane level indicators.

Transmission

Allison 6 speeds forward, 1 reverse
2 speed transfer case

Drive/Steer

10x8x10

Axles

1st axle line – steer
2nd axle line – steer/(optional drive)
3rd axle line – drive/steer (permanent drive with 10x6, disconnects for highway with 10x8)
4th axle line – drive/steer (connects for all wheel steer)
5th axle line – drive/steer

Drive axles with planetary hub reduction and center mounted gearing. Standard inter-axle and cross axle differential locks.

Suspension

Grove exclusive MEGATRAK suspension. Independent hydro-pneumatic system acting on all wheels with hydraulic lockout. Suspension can be raised 6.3" (160 mm) or lowered 4.7" (120 mm), both longitudinally and transversely. Features an automatic leveling system for highway travel.

Tires

10 tires, 16.00R25 (Vehicle width – 10.2' [3.1 m])

Steering

Dual circuit, hydraulic power assisted steering system. Transfer case mounted, ground driven emergency steering pump. Axles 1, 2, 3 and 5 steer on highway. Separate steering of the 4th and 5th axles for all wheel and crab steering, controlled by an electronic rocker switch.

Engine

Mercedes OM 502 LA, 8 cylinder
Horsepower: 563 bhp (420 kW) at 1800 rpm
Torque: 1991 ft.;b/ (2700 Nm) at 1200 rpm
Off-road: EPA/CARB/EUROMOT (III)

Fuel Tank Capacity

136 gallons (515 L). Supplies superstructure and carrier engines.

Brakes

Service brakes: pneumatic dual circuit acting on all wheels.
Parking brake: pneumatically operated spring loaded brake acting on axle lines 2,3,4 and 5.
Air dryer.

Cab

Two-man, aluminum construction with the following features: safety glass, driver and passenger seats with hydraulic suspension, engine-dependent hot water heater, power windows, heated rear view mirrors, complete instrumentation and driving controls.

Electrical System

24V system with three phase alternator, 28V/100A
2 batteries, 12V/170 Ah

Maximum Speed

53 mph (85 kph)

Gradeability (Theoretical)

50% - 14.00 tires
45% - 16.00/20.5 tires

Miscellaneous Standard Equipment

Work light; tool kit; fire extinguishers; auxiliary boom nose; radio /CD player in carrier cab, heated rear view mirrors, wind speed indicator.

*Optional Equipment

- *Timer for diesel heater
- *Stainless steel exhaust system with spark arrestor
- *Air conditioning
- *14.00R25 tires (vehicle width 9.8 ft.[3.0 m])
- *20.5R25 tires (vehicle width 10.2 ft.[3.1 m])
- *10x6x10 drive/steer
- *Transmission retarder (in lieu of engine compression brake)
- *Engine independent diesel cab heater, with engine pre-heater
- *Strobe light
- *Work lights for outriggers
- *Spare tire and wheel with carry bracket
- *Aluminum edging for decking
- *Rear mounted stowage box
- *Outrigger pad load indicator
- *Trailer hitch
- *Steel outrigger pads

*Denotes optional equipment

GMK5275

GROVE

dimensions

9

Weights & Dimensions – European Version

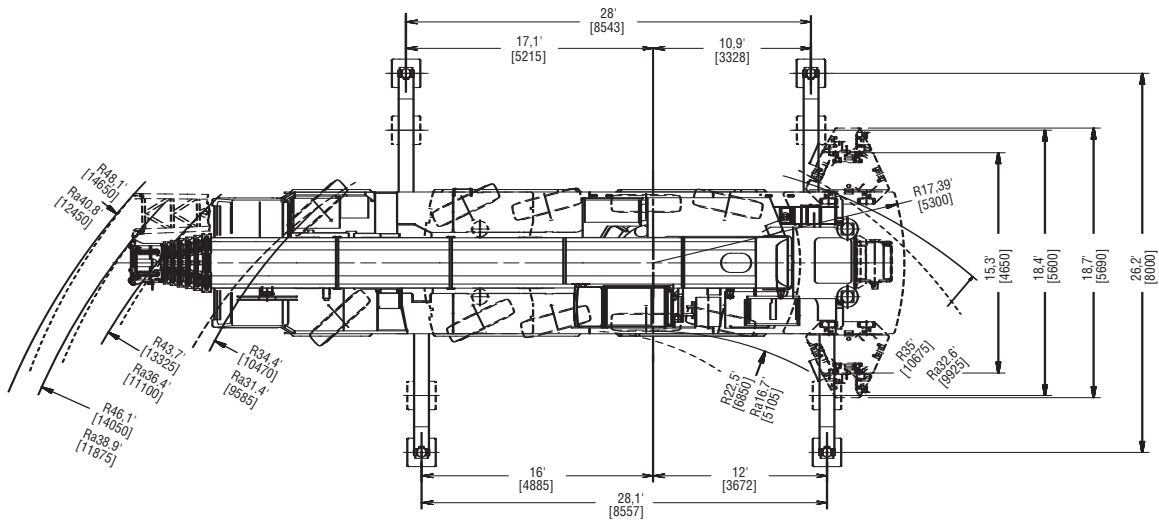
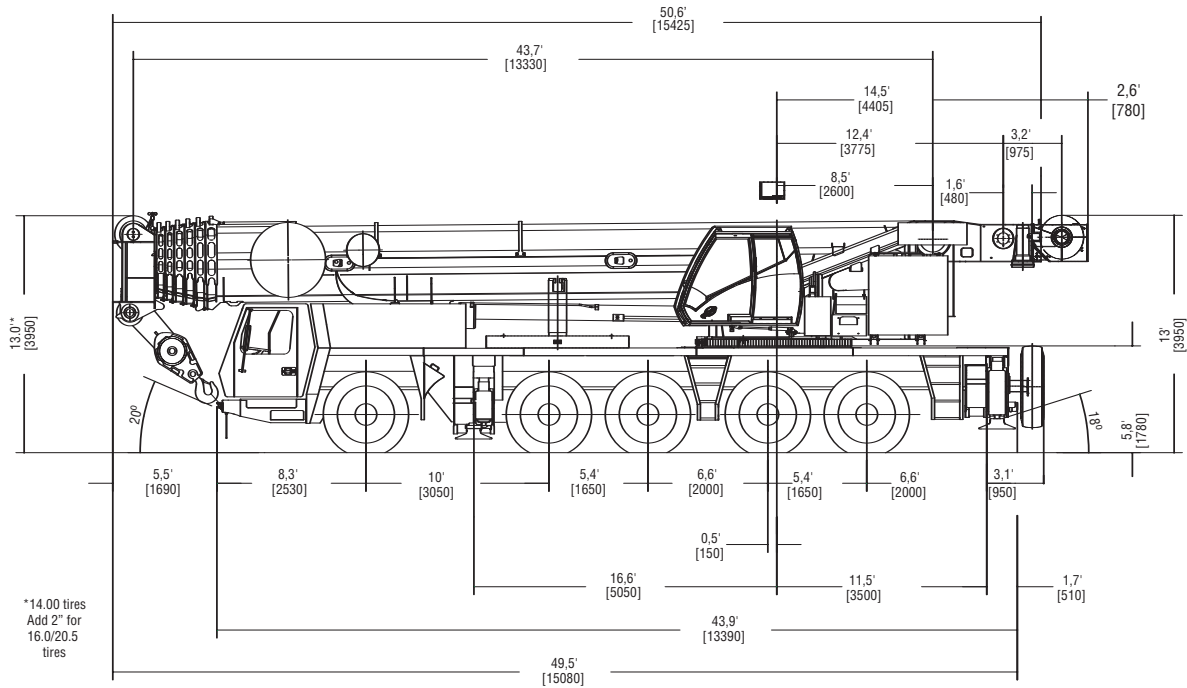

Basic Weights - lb. (kg.)	Axles 1-3	Axles 4 & 5	Total
Mercedes power, 14.00 tires, 10X6X10 drive/steer and driver.	74,810 (33934)	53,354 (24201)	128,164 (58135)
Additions:			
10X8X10 drive /steer	316 (316)	39 (39)	739 (355)
14.00R25 spare tire with bracket	-357 (-162)	941 (427)	584 (265)
16.00R25 spare tire with bracket	-439 (-199)	1,155 (524)	717 (325)
20.5R25 spare tire with bracket	-496 (-225)	1,305 (592)	809 (367)
Brackets and hose reel for swingaway	950 (431)	-355 (-161)	595 (270)
39 ft. - 69 ft. (12 m - 21 m) swingaway	5,117 (2321)	-686 (-311)	4,431 (-2,010)
Auxiliary hoist	-3,124 (-1417)	6,960 (3157)	3,836 (1740)
Substitutions:			
16.00R25 tires	904 (410)	419 (190)	1,323 (600)
20.5R25 tires	1,534 (696)	714 (324)	2,249 (1020)
Remove:			
Boom assembly	-43,270 (-19627)	-3,369 (-1528)	-46,639 (-21155)
Front outriggers	-4,828 (-2190)	661 (300)	-4,167 (-1890)
Rear outriggers	2,950 (1338)	-8,109 (-3678)	-5,159 (-2340)
Front and rear outrigger floats	-130 (-59)	-311 (-141)	-441 (-200)

GMK5275

GROVE.

trailing boom proposal

Trailing Boom Weights – European Version

10

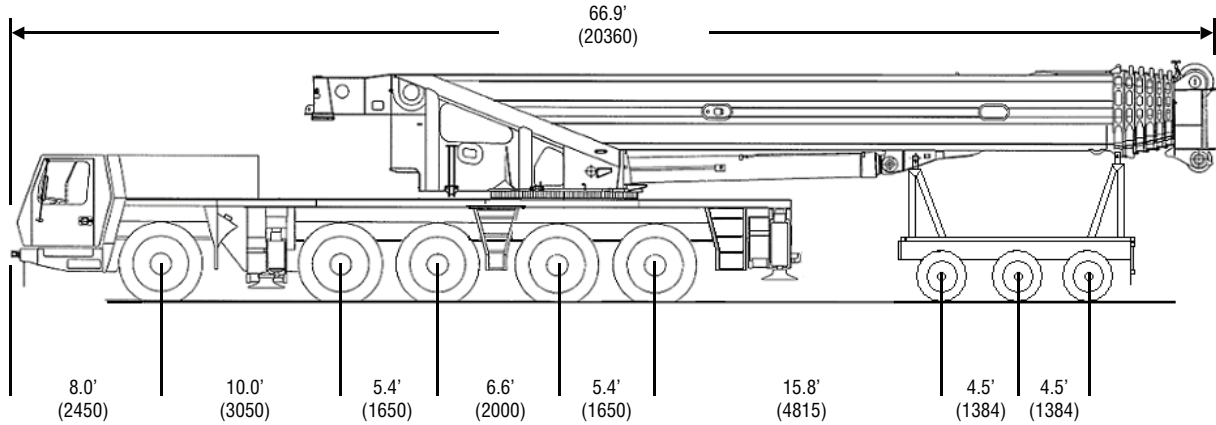

Basic Weights - lb. (kg.)	Axes 1-3		Axes 4 & 5		Dolly		Total	
Mercedes power, 16.00 tires, 10X8X10 drive/steer, outrigger pads stowed, auxiliary hoist, 69 ft. swingaway stowed, additional oil cooler, 9500 lb. dolly.	60,835 (27594)		44,060 (19985)		44,265 (20078)		149,160 (67658)	
Substitutions								
14.00R25 tires	-904	(-410)	-419	(-190)	-	-	-1,323	(-600)
20.5R25 tires	631	(286)	295	(134)	-	-	926	(420)
10X6X10 drive/steer	-697	(-316)	-86	(-39)	-	-	-783	(-355)
Remove:								
39 ft. - 69 ft. (12 - 21 m) swingaway	-761	(-345)	-388	(-176)	-3,283	(-1489)	-4,431	(-2010)
Auxiliary hoist	-4,173	(-1893)	337	(153)	-	-	-3,836	(-1740)
Front outriggers	-4,828	(-2190)	661	(300)	-	-	-4,167	(-1890)
Rear outriggers	2,950	(1338)	-8,109	(-3678)	-	-	-5,159	(-2340)
Front and rear outrigger floats	-130	(-59)	-311	(-141)	-	-	-441	(-200)

GMK5275

GROVE

counterweight

11

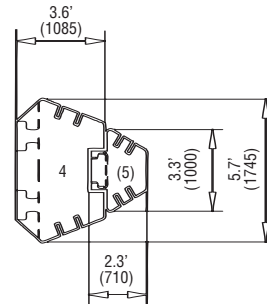
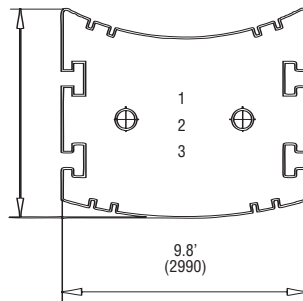
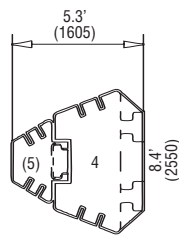
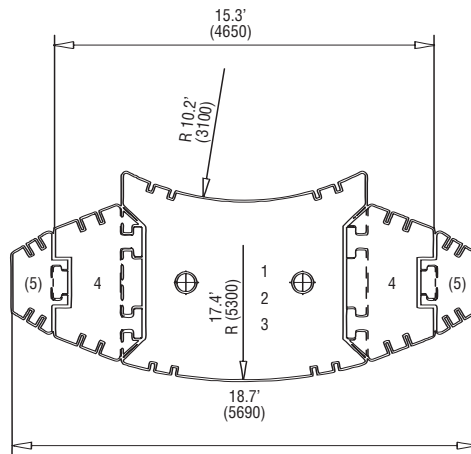
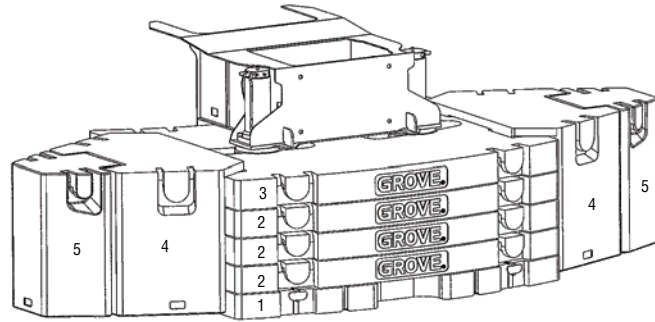

Counterweight Configuration lb. (kg)

	1 (Baseplate)	2 (Stackable)	3 (Stackable)	4 (Wing)	5 (Wing)
	24,200 (11 000)	22,046 (10 000)	22,046 (10 000)	22,046 (10 000)	6,600 (3 000)

	()	•			
	()	•	•		
8	()	•	X		
9	()	•	X		
	()	•	X	•	
	(7)	•	X	•	X
9 7	(77)	•	X	•	X

GMK5275

working range

44'-223' Main Boom

12

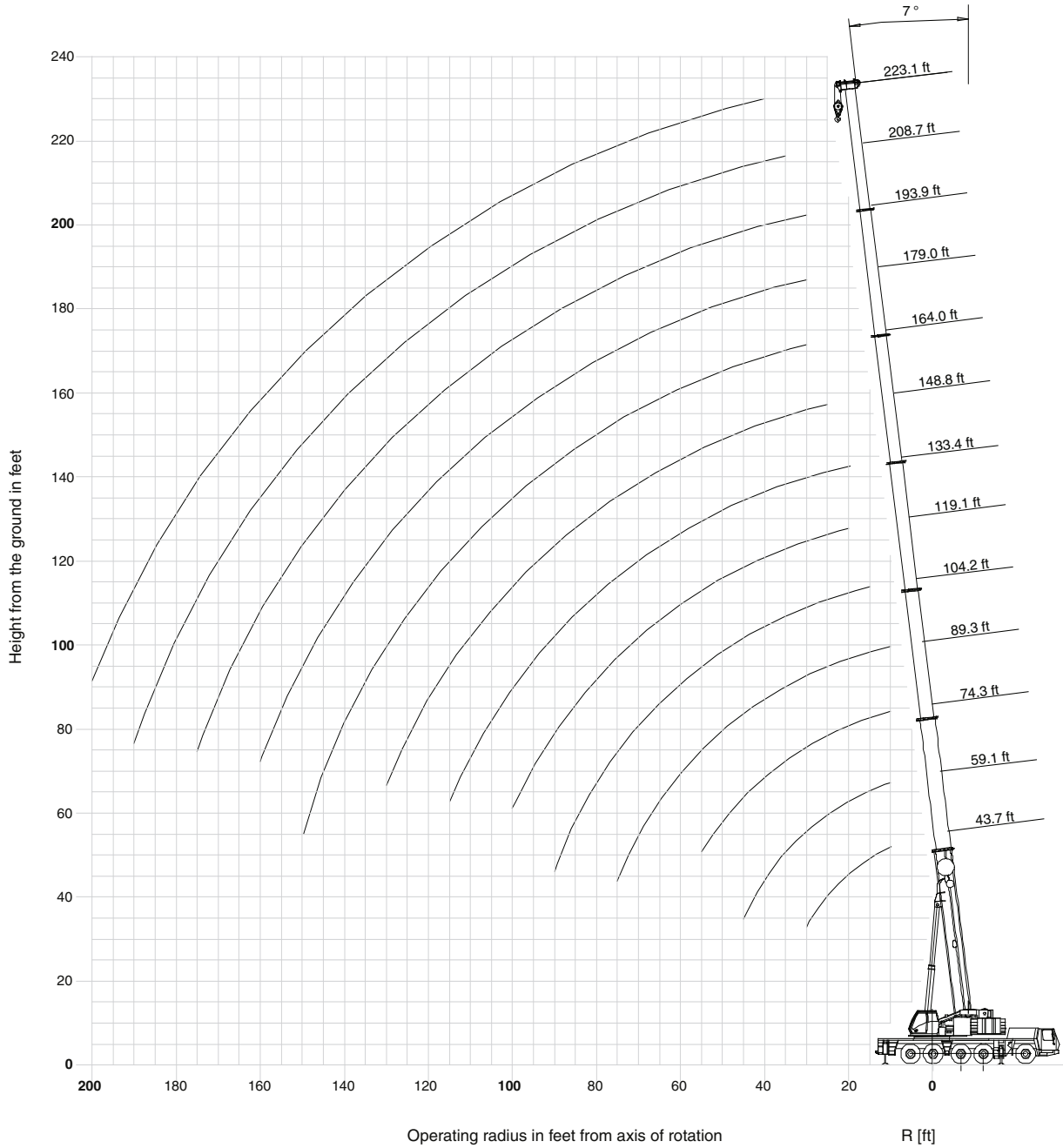



GMK5275

GROVE

THIS CHART IS ONLY A GUIDE AND SHOULD NOT BE USED TO OPERATE THE CRANE. The individual crane's load chart, operating instructions and other instructional plates must be read and understood prior to operating the crane.

load charts

44-223 ft.
 (13.3-68 m)

169,700 lbs.
 (77,000 kg)

100%
26'-7" spread

360°



Pounds x 1000

13

Feet	43.7'	59.1'	74.3'	89.3'	104.2'	119.1'	133.4'	148.8'	164.0'	179.0'	193.9'	208.7'	223.1'
8	*550.0												
10	346.0	332.0	312.0	244.0									
15	272.0	270.0	260.0	242.0	185.0								
20	220.0	222.0	215.0	212.0	182.0	144.0	106.0						
25	184.0	185.0	181.0	181.0	166.0	140.0	106.0	86.0					
30	152.0	157.0	157.0	155.0	151.0	129.0	105.0	86.0	69.0	55.0	45.0		
35		136.0	136.0	135.0	136.0	118.0	96.0	86.0	69.0	55.0	45.0	36.4	
40		121.0	119.0	118.0	120.0	108.0	88.0	82.0	69.0	55.0	45.0	36.4	30.8
45		99.0	106.0	104.0	106.0	99.0	81.0	75.0	68.0	55.0	45.0	36.4	30.8
50			95.0	93.0	95.0	92.0	76.0	70.0	63.0	55.0	45.0	36.4	30.8
55			83.0	84.0	85.0	85.0	72.0	64.0	59.0	52.0	45.0	36.4	30.8
60				76.0	77.0	79.0	67.0	59.0	54.0	49.0	44.0	36.4	30.8
65				70.0	70.0	72.0	63.0	54.0	50.0	46.0	41.2	36.4	30.8
70				63.0	64.0	66.0	60.0	50.0	47.0	43.4	39.0	36.0	30.8
75				50.0	58.0	61.0	57.0	46.0	43.0	40.4	36.8	34.4	30.8
80					53.0	55.0	54.0	42.8	39.6	37.6	34.8	32.6	30.4
85					49.0	51.0	51.0	40.2	37.2	35.2	33.0	31.0	29.2
90					39.2	46.0	48.0	37.6	34.6	32.8	31.2	29.4	28.0
95						42.4	44.0	35.2	32.4	30.8	29.4	28.0	26.8
100						38.2	40.8	33.2	30.4	28.8	27.8	26.4	25.6
105							37.6	31.4	28.8	27.2	26.4	24.8	24.4
110							34.8	29.6	27.0	25.6	24.8	23.0	23.2
115							30.4	28.0	25.2	23.8	23.0	21.4	22.0
120								26.6	23.2	21.8	21.2	20.4	20.8
125								25.2	21.4	20.0	19.4	19.4	19.4
130								24.4	20.2	19.0	18.4	18.4	18.0
135									19.2	18.0	17.4	17.4	17.2
140									18.2	17.0	16.4	16.6	16.4
145									17.2	16.0	15.6	15.8	15.6
150									12.8	15.4	14.8	15.0	15.0
155										14.8	14.0	14.2	14.2
160										14.4	13.2	13.4	13.6
165											12.6	12.8	13.0
170											11.8	12.2	12.4
175											11.4	11.6	11.8
180												11.0	11.2
185												10.6	10.6
190												9.6	10.2
195													9.6
200													9.2

* Over the rear with special equipment

"Loads greater than 297,000 lb. can only be lifted with additional equipment"

"Loads greater than 335,000 lb. can only be lifted with special equipment"

GMK5275

load charts





14

 **44-223 ft.**
 (13.3-68 m)
  **112,400 lbs.**
 (51,000 kg)
  **100%**
26'-7" spread
 **360°**



Pounds (thousands)

Feet	43.7'	59.1'	74.3'	89.3'	104.2'	119.1'	133.4'	148.8'	164.0'	179.0'	193.9'	208.7'	223.1'
10	336.0	332.0	312.0	244.0									
15	262.0	260.0	258.0	242.0	185.0								
20	210.0	211.0	208.0	210.0	182.0	144.0	106.0						
25	176.0	177.0	176.0	175.0	166.0	140.0	106.0	86.0					
30	149.0	150.0	150.0	148.0	150.0	129.0	105.0	86.0	69.0	55.0	45.0		
35		132.0	130.0	127.0	124.0	118.0	96.0	86.0	69.0	55.0	45.0	36.4	
40		114.0	111.0	110.0	103.0	102.0	88.0	82.0	69.0	55.0	45.0	36.4	30.8
45		98.0	95.0	94.0	90.0	88.0	81.0	75.0	68.0	55.0	45.0	36.4	30.8
50			83.0	82.0	81.0	76.0	76.0	70.0	63.0	55.0	45.0	36.4	30.8
55			72.0	71.0	72.0	67.0	68.0	64.0	59.0	52.0	45.0	36.4	30.8
60				62.0	64.0	62.0	60.0	57.0	54.0	49.0	44.0	36.4	30.8
65				57.0	56.0	58.0	54.0	50.0	49.0	46.0	41.2	36.4	30.8
70				51.0	50.0	52.0	49.0	45.0	43.8	43.2	39.0	36.0	30.8
75				46.0	45.0	47.0	44.0	40.8	39.6	39.0	36.8	34.4	30.8
80					41.6	42.0	40.0	37.0	35.8	35.4	34.8	32.6	30.4
85					39.2	38.2	36.0	34.2	32.4	32.0	32.0	31.0	29.2
90						34.6	32.6	32.8	29.4	29.2	29.2	29.4	28.0
95						31.4	29.4	31.4	26.8	26.6	26.6	27.4	26.8
100							28.8	26.8	28.6	24.4	24.4	25.0	25.6
105								25.2	26.0	22.2	22.8	23.0	23.6
110								24.2	23.8	20.0	21.2	21.2	21.8
115								23.4	21.8	18.4	20.2	19.0	20.2
120								20.0	17.8	19.4	18.0	18.6	18.6
125								18.4	17.0	18.4	17.2	17.6	17.2
130								16.8	16.2	17.8	16.4	16.6	15.8
135									15.6	16.8	15.8	15.8	14.6
140									15.0	15.4	15.0	14.8	13.4
145										14.4	14.2	13.6	12.4
150										13.2	13.2	12.6	11.2
155										12.2	12.2	11.4	10.2
160										11.4	11.2	10.6	9.2
165											10.6	9.6	8.4
170											9.8	8.8	7.6
175											9.2	8.0	6.8
180												7.2	6.0
185												6.6	5.2
190												6.0	4.6
195													4.0
200													3.4

 **44-223 ft.**
 (13.3-68 m)
  **90,300 lbs.**
 (41,000 kg)
  **100%**
26'-7" spread
 **360°**



Pounds (thousands)

Feet	43.7'	59.1'	74.3'	89.3'	104.2'	119.1'	133.4'	148.8'	164.0'	179.0'	193.9'	208.7'	223.1'
10	332.0	328.0	312.0	244.0									
15	256.0	256.0	254.0	242.0	185.0								
20	207.0	208.0	206.0	206.0	182.0	144.0	106.0						
25	172.0	173.0	173.0	171.0	166.0	140.0	106.0	86.0					
30	146.0	149.0	146.0	138.0	131.0	128.0	105.0	86.0	69.0	55.0	45.0		
35		124.0	117.0	114.0	110.0	105.0	96.0	86.0	69.0	55.0	45.0	36.4	
40		102.0	101.0	95.0	94.0	88.0	87.0	82.0	69.0	55.0	45.0	36.4	30.8
45		84.0	85.0	81.0	80.0	76.0	75.0	71.0	68.0	55.0	45.0	36.4	30.8
50			72.0	72.0	70.0	70.0	65.0	61.0	59.0	55.0	45.0	36.4	30.8
55			64.0	64.0	61.0	62.0	57.0	54.0	52.0	51.0	45.0	36.4	30.8
60				55.0	56.0	55.0	51.0	47.0	46.0	45.0	44.0	36.4	30.8
65				49.0	51.0	49.0	45.0	42.0	40.6	40.0	39.6	36.4	30.8
70				43.6	45.0	44.0	40.6	39.8	36.2	35.6	35.4	36.0	30.8
75					38.4	40.6	39.4	36.4	37.6	32.4	32.0	31.8	32.4
80						36.6	35.4	33.0	34.0	29.0	29.4	30.2	29.8
85						33.0	31.6	30.0	31.0	26.4	28.2	27.8	28.6
90							29.8	28.6	28.4	25.0	27.0	26.2	26.6
95								25.8	27.4	25.6	25.6	24.6	24.4
100								23.4	25.2	23.2	21.2	24.0	22.4
105									22.8	21.0	20.4	20.8	20.6
110									21.0	19.0	19.4	19.8	18.8
115									19.2	17.2	18.4	18.6	17.4
120									16.0	17.8	17.0	17.0	16.0
125									15.2	17.0	15.8	16.0	14.6
130									14.6	15.8	15.0	14.6	13.4
135										14.6	14.2	13.4	12.2
140										13.4	13.0	12.2	11.2
145											12.0	11.2	10.0
150											11.0	10.2	9.0
155											10.2	9.2	8.2
160											9.4	8.4	7.4
165												7.6	6.6
170												7.0	5.8
175												6.2	5.2
180													4.4
185													3.8
190													3.2
195													
200													

Loads greater than 297,000 lb. can only be lifted with additional equipment
 Loads greater than 335,000 lb. can only be lifted with special equipment

GMK5275

load charts

15

44-223 ft.
(13.3-68 m)

46,200 lbs.
(21,000 kg)

100%
26'-7" spread

360°



Pounds (thousands)

Feet	43.7'	59.1'	74.3'	89.3'	104.2'	119.1'	133.4'	148.8'	164.0'	179.0'	193.9'	208.7'	223.1'
10	320.0	318.0	312.0	244.0									
15	248.0	248.0	246.0	242.0	185.0								
20	199.0	200.0	187.0	175.0	158.0	144.0	106.0						
25	154.0	148.0	138.0	128.0	123.0	113.0	106.0	86.0					
30	114.0	111.0	105.0	103.0	96.0	94.0	87.0	81.0	69.0	55.0	45.0		
35		90.0	87.0	83.0	82.0	77.0	71.0	66.0	63.0	55.0	45.0	36.4	
40		72.0	72.0	68.0	68.0	64.0	59.0	59.0	52.0	51.0	45.0	36.4	30.8
45		58.0	60.0	61.0	58.0	54.0	50.0	51.0	43.8	43.0	42.0	36.4	30.8
50			50.0	52.0	50.0	47.0	45.0	43.4	39.2	40.6	39.6	36.0	30.8
55			45.0	46.0	43.2	40.2	41.2	37.4	36.8	37.4	36.6	34.0	30.8
60				39.2	37.8	36.0	36.0	32.6	34.6	34.0	32.2	29.8	27.4
65				33.8	33.2	33.8	31.8	30.6	31.4	30.2	28.4	26.2	24.0
70				29.4	29.0	30.6	28.2	29.0	28.4	26.8	25.2	23.2	21.0
75				22.8	25.4	27.4	25.0	27.0	25.4	24.0	22.4	20.4	18.4
80					22.2	24.2	23.2	24.4	23.0	21.4	20.0	18.2	16.2
85					22.0	21.4	20.8	22.0	20.6	19.2	17.8	16.0	14.2
90					19.6	19.0	19.4	20.0	18.6	17.2	16.0	14.2	12.4
95						17.4	18.4	18.0	16.8	15.6	14.2	12.6	10.8
100						16.6	16.4	16.2	15.2	14.0	12.6	11.0	9.2
105							14.8	14.6	13.8	12.6	11.2	9.8	8.0
110							13.4	13.0	12.4	11.2	10.0	8.4	6.8
115							12.0	11.6	11.0	10.0	8.8	7.4	5.6
120								10.4	9.8	9.0	7.8	6.4	4.6
125								9.4	8.6	8.0	6.8	5.4	3.8
130								8.4	7.6	7.0	6.0	4.6	2.8
135									6.8	6.0	5.2	3.8	
140									6.0	5.2	4.4	3.0	
145										4.4	3.6		
150										3.6	2.8		
155										3.0			
160													

44-223 ft.
(13.3-68 m)

0

100%
26'-7" spread

360°



Pounds (thousands)

Feet	43.7'	59.1'	74.3'	89.3'	104.2'	119.1'	133.4'	148.8'	164.0'	177.6	192.6
10	308.0	308.0	286.0	232.0							
15	222.0	185.0	160.0	144.0	125.0						
20	122.0	114.0	105.0	100.0	90.0	79.0	76.0				
25	81.0	80.0	77.0	72.0	65.0	63.0	57.0	56.0			
30	56.0	58.0	57.0	54.0	53.0	49.0	48.0	45.0	41.2	37.6	34.4
35		44.0	44.0	44.0	42.4	41.2	38.8	36.4	33.4	30.6	28.0
40		34.2	35.6	36.0	35.0	33.8	32.0	30.0	27.6	25.2	22.8
45		27.4	28.8	29.6	29.0	28.0	26.6	25.0	23.0	20.8	18.8
50			23.8	24.8	24.2	23.6	22.4	21.0	19.2	17.2	15.4
55			19.8	20.8	20.4	20.0	19.0	17.8	16.2	14.4	12.8
60				17.6	17.4	17.0	16.2	15.0	13.6	12.0	10.4
65				15.0	14.8	14.6	13.8	12.8	11.4	9.8	8.4
70				12.6	12.6	12.4	11.8	10.8	9.4	8.0	6.8
75				5.8	10.8	10.6	10.0	9.2	7.8	6.6	5.2
80					9.2	9.0	8.4	7.6	6.4	5.2	4.0
85					7.6	7.8	7.2	6.4	5.2	4.0	2.8
90					6.2	6.6	6.0	5.2	4.0	2.8	
95						5.4	4.8	4.2	3.0		
100						4.4	4.0	3.2			
105							3.2				
110											
115											
120											

Loads greater than 297,000 lb. can only be lifted with additional equipment
 Loads greater than 335,000 lb. can only be lifted with special equipment

THIS CHART IS ONLY A GUIDE AND SHOULD NOT BE USED TO OPERATE THE CRANE. The individual crane's load chart, operating instructions and other instructional plates must be read and understood prior to operating the crane.

GMK5275

GROVE

working range

223' Main Boom with 39.4 ft. and 68.9 ft. Swingaway

16

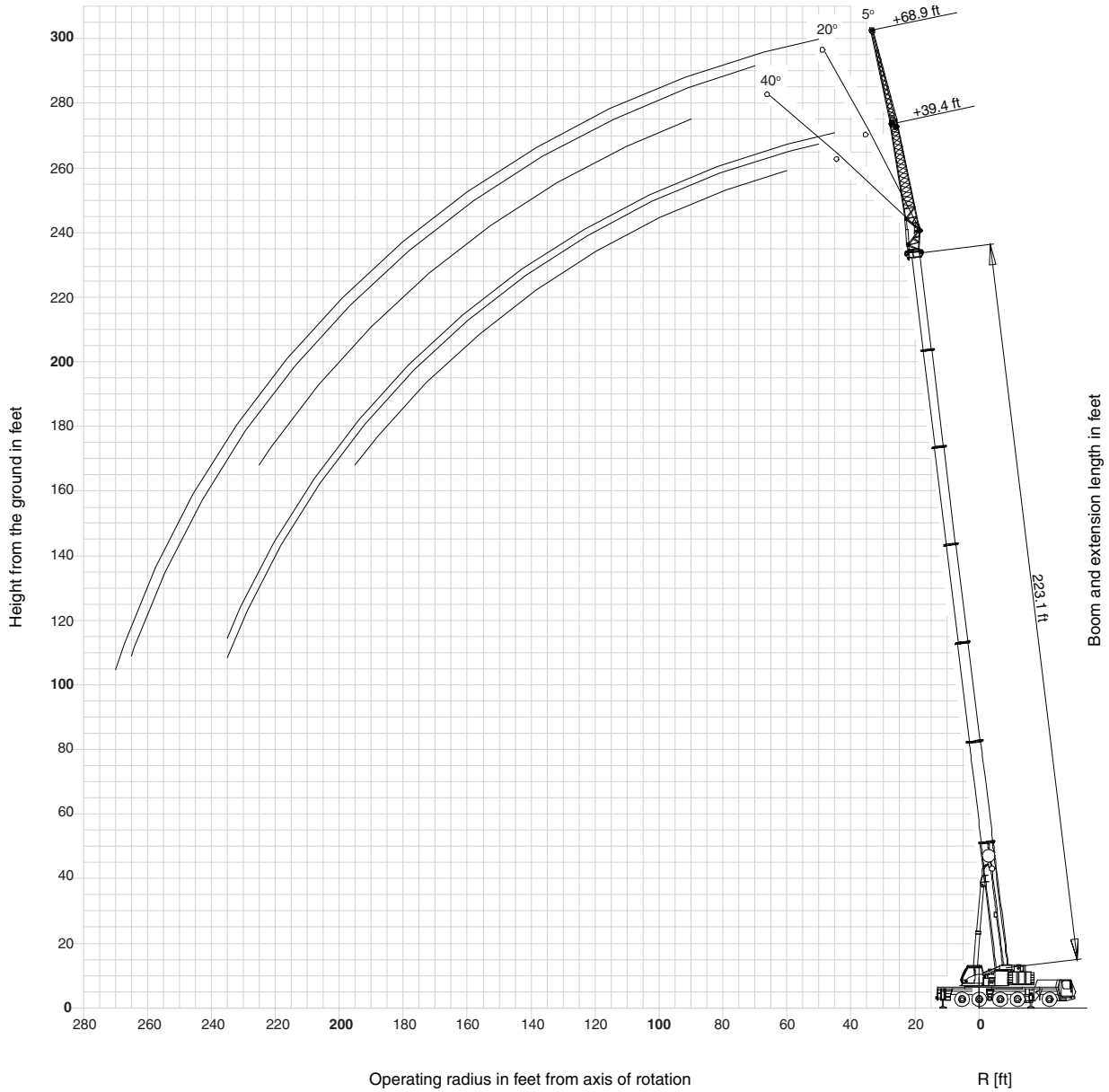

GMK5275

GROVE

THIS CHART IS ONLY A GUIDE AND SHOULD NOT BE USED TO OPERATE THE CRANE. The individual crane's load chart, operating instructions and other instructional plates must be read and understood prior to operating the crane.

working range

223' Main Boom, 68.9' Swingaway and 2 x 26 ft. Inserts

17

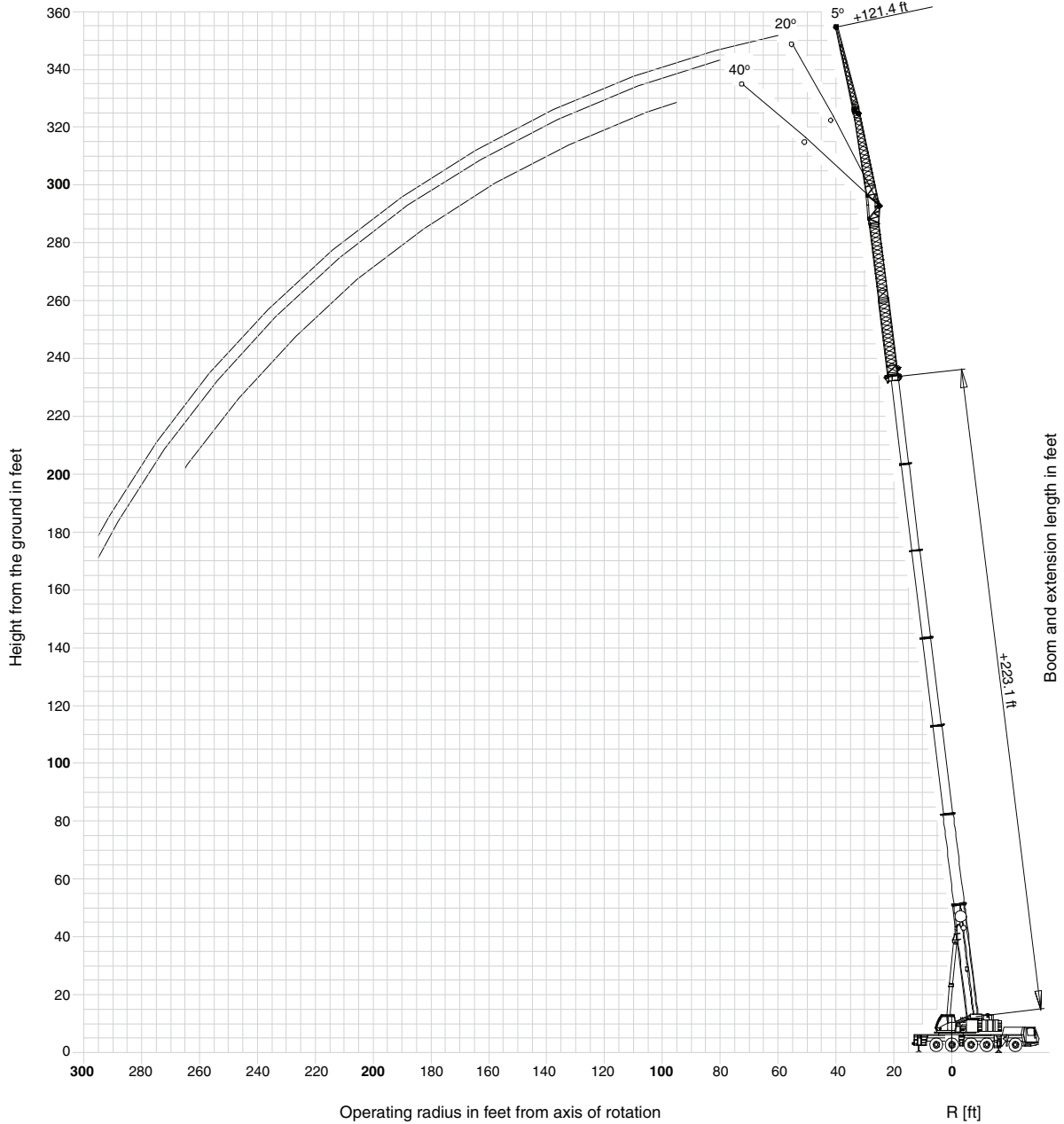

GMK5275

THIS CHART IS ONLY A GUIDE AND SHOULD NOT BE USED TO OPERATE THE CRANE. The individual crane's load chart, operating instructions and other instructional plates must be read and understood prior to operating the crane.

GROVE

load charts

18



223 ft.
(68 m)



39.4-68.9-95.1-121.4 lbs.
(12-21-29-37 m)



169,700 lbs.
(77,000 kg)



100%
26'-7" spread



360°



Pounds (thousands)

Radius	223' + 39.4'			223' + 68.9'			223' + 95.1'			223' + 121.4'		
	5°	5°-20°	20°-40°	5°	5°-20°	20°-40°	5°	5°-20°	20°-40°	5°	5°-20°	20°-40°
	x 1000 lb.											
45	16.4											
50	16.4	16.4		10.0								
55	16.4	16.4		10.0			7.4					
60	16.4	16.4	16.4	10.0			7.4			5.0		
65	16.4	16.4	16.4	10.0			7.4			5.0		
70	16.4	16.4	16.4	10.0	10.0		7.4			5.0		
75	16.4	16.4	16.4	10.0	10.0		7.4	7.4		5.0		
80	16.4	16.4	16.4	10.0	10.0		7.4	7.4		5.0	5.0	
85	16.4	16.4	16.0	10.0	10.0		7.4	7.4		5.0	5.0	
90	16.4	16.2	15.6	10.0	10.0	9.4	7.4	7.4		5.0	5.0	
95	16.4	15.8	15.2	10.0	10.0	9.4	7.4	7.4	7.2	5.0	5.0	4.0
100	16.0	15.2	14.8	10.0	10.0	9.2	7.4	7.4	7.2	5.0	5.0	4.0
105	15.6	14.8	14.4	10.0	10.0	9.2	7.4	7.4	7.2	5.0	5.0	4.0
110	15.0	14.4	14.0	10.0	10.0	9.2	7.4	7.4	7.2	5.0	5.0	4.0
115	14.4	13.8	13.6	10.0	10.0	9.0	7.4	7.4	7.2	5.0	5.0	4.0
120	14.0	13.4	13.2	10.0	10.0	9.0	7.4	7.4	7.2	5.0	5.0	4.0
125	13.6	13.0	12.8	10.0	10.0	9.0	7.4	7.4	7.2	5.0	5.0	4.0
130	13.2	12.6	12.4	10.0	9.8	8.8	7.4	7.4	7.2	5.0	5.0	4.0
135	12.8	12.2	12.2	10.0	9.6	8.8	7.4	7.4	7.2	5.0	5.0	4.0
140	12.4	12.0	11.8	9.8	9.4	8.8	7.4	7.2	7.0	5.0	5.0	4.0
145	12.0	11.6	11.4	9.4	9.0	8.6	7.4	7.2	7.0	5.0	5.0	4.0
150	11.6	11.2	11.2	9.2	8.8	8.6	7.4	7.0	6.8	5.0	4.8	4.0
155	11.2	11.0	11.0	9.0	8.6	8.4	7.2	6.8	6.6	5.0	4.8	4.0
160	11.0	10.6	10.6	8.6	8.4	8.2	7.0	6.6	6.6	5.0	4.8	4.0
165	10.6	10.4	10.4	8.4	8.2	8.0	6.8	6.6	6.4	4.8	4.8	4.0
170	10.2	10.2	10.2	8.2	8.0	8.0	6.6	6.4	6.2	4.8	4.6	4.0
175	9.8	9.8	10.0	8.0	7.8	7.8	6.4	6.2	6.2	4.8	4.6	4.0
180	9.6	9.6	9.6	7.8	7.6	7.6	6.2	6.0	6.0	4.6	4.6	4.0
185	9.2	9.2	9.4	7.6	7.4	7.4	6.0	5.8	5.8	4.6	4.4	4.0
190	8.8	8.8	9.0	7.4	7.2	7.2	5.8	5.6	5.8	4.4	4.4	4.0
195	8.2	8.4	8.6	7.2	7.0	7.0	5.6	5.6	5.6	4.2	4.2	4.0
200	8.0	8.0		7.0	6.8	6.8	5.4	5.4	5.4	4.2	4.0	4.0
205	7.6	7.8		6.8	6.6	6.8	5.2	5.2	5.4	4.0	4.0	4.0
210	7.2	7.4		6.6	6.4	6.6	5.0	5.0	5.2	3.8	3.8	4.0
215	6.8	7.0		6.4	6.4	6.4	5.0	5.0	5.0	3.6	3.8	3.8
220	6.4	6.6		6.2	6.2	6.4	4.8	4.8	5.0	3.6	3.6	3.8
225	6.2	6.2		6.0	6.0	6.2	4.6	4.6	4.8	3.4	3.4	3.6
230	5.8	6.0		5.8	6.0		4.6	4.6	4.6	3.2	3.4	3.6
235	5.4	5.6		5.6	5.8		4.4	4.4	4.6	3.2	3.2	3.4
240				5.2	5.6		4.2	4.2	4.4	3.0	3.2	3.2
245				5.0	5.2		4.2	4.2	4.2	3.0	3.0	3.2
250				4.8	5.0		4.0	4.0		2.8	2.8	3.0
255				4.4	4.6		3.8	4.0		2.8	2.8	3.0
260				4.2	4.4		3.8	3.8		2.6	2.6	2.8
265				4.0	4.0		3.6	3.6		2.6	2.6	2.8
270				3.2			3.4	3.6		2.4	2.4	
275							3.2	3.4		2.4	2.4	
280							3.0	3.0		2.2	2.2	
285							2.6	2.6		2.2	2.2	
290							2.2	2.2		2.0	2.2	
295										2.0	2.0	

GMK5275

GROVE

THIS CHART IS ONLY A GUIDE AND SHOULD NOT BE USED TO OPERATE THE CRANE. The individual crane's load chart, operating instructions and other instructional plates must be read and understood prior to operating the crane.

load charts



223 ft.
(68 m)



39.4-68.9-95.1-121.4 lbs.
(12-21-29-37 m)



112,400 lbs.
(51,000 kg)



100%
26'-7" spread



360°



Pounds (thousands)

19

Radius	223' + 39.4'			223' + 68.9'			223' + 95.1'			223' + 121.4'		
	5°	5°-20°	20°-40°	5°	5°-20°	20°-40°	5°	5°-20°	20°-40°	5°	5°-20°	20°-40°
	x 1000 lb.											
45	16.4											
50	16.4	16.4		10.0								
55	16.4	16.4		10.0			7.4					
60	16.4	16.4	16.4	10.0			7.4			5.0		
65	16.4	16.4	16.4	10.0			7.4			5.0		
70	16.4	16.4	16.4	10.0	10.0		7.4			5.0		
75	16.4	16.4	16.4	10.0	10.0		7.4	7.4		5.0		
80	16.4	16.4	16.4	10.0	10.0		7.4	7.4		5.0	5.0	
85	16.4	16.4	16.0	10.0	10.0		7.4	7.4		5.0	5.0	
90	16.4	16.2	15.6	10.0	10.0	9.4	7.4	7.4		5.0	5.0	
95	16.4	15.8	15.2	10.0	10.0	9.4	7.4	7.4	7.2	5.0	5.0	4.0
100	16.0	15.2	14.8	10.0	10.0	9.2	7.4	7.4	7.2	5.0	5.0	4.0
105	15.6	14.8	14.4	10.0	10.0	9.2	7.4	7.4	7.2	5.0	5.0	4.0
110	15.0	14.4	14.0	10.0	10.0	9.2	7.4	7.4	7.2	5.0	5.0	4.0
115	14.4	13.8	13.6	10.0	10.0	9.0	7.4	7.4	7.2	5.0	5.0	4.0
120	14.0	13.4	13.2	10.0	10.0	9.0	7.4	7.4	7.2	5.0	5.0	4.0
125	13.6	13.0	12.8	10.0	10.0	9.0	7.4	7.4	7.2	5.0	5.0	4.0
130	13.2	12.6	12.4	10.0	9.8	8.8	7.4	7.4	7.2	5.0	5.0	4.0
135	12.8	12.2	12.2	10.0	9.6	8.8	7.4	7.4	7.2	5.0	5.0	4.0
140	12.4	12.0	11.8	9.8	9.4	8.8	7.4	7.2	7.0	5.0	5.0	4.0
145	12.0	11.6	11.4	9.4	9.0	8.6	7.4	7.2	7.0	5.0	5.0	4.0
150	11.2	11.2	11.2	9.2	8.8	8.6	7.4	7.0	6.8	5.0	4.8	4.0
155	10.2	10.2	10.8	9.0	8.6	8.4	7.2	6.8	6.6	5.0	4.8	4.0
160	9.4	9.4	10.0	8.6	8.4	8.2	7.0	6.6	6.6	5.0	4.8	4.0
165	8.6	8.6	9.2	8.4	8.2	8.0	6.8	6.6	6.4	4.8	4.8	4.0
170	7.8	7.8	8.4	8.2	8.0	8.0	6.6	6.4	6.2	4.8	4.6	4.0
175	7.0	7.0	7.6	8.0	7.8	7.8	6.4	6.2	6.2	4.8	4.6	4.0
180	6.4	6.4	6.8	7.2	7.2	7.6	6.2	6.0	6.0	4.6	4.6	4.0
185	5.6	5.6	6.0	6.6	6.6	7.4	6.0	5.8	5.8	4.6	4.4	4.0
190	5.0	5.0	5.4	6.0	6.0	6.8	5.8	5.6	5.8	4.4	4.4	4.0
195	4.4	4.4	4.8	5.4	5.4	6.2	5.4	5.4	5.6	4.2	4.2	4.0
200	3.8	3.8		4.8	4.8	5.6	4.8	4.8	5.4	4.2	4.0	4.0
205	3.2	3.2		4.4	4.4	5.0	4.2	4.2	5.0	4.0	4.0	4.0
210	2.6	2.6		3.8	3.8	4.4	3.8	3.8	4.4	3.6	3.6	4.0
215	2.2	2.2		3.2	3.2	3.8	3.2	3.2	4.0	3.2	3.2	3.8
220				2.8	2.8	3.4	2.8	2.8	3.4	2.6	2.6	3.4
225				2.2	2.2	2.8	2.4	2.4	3.0	2.2	2.2	3.0
230							2.0	2.0	2.6			2.4
235									2.2			2.0

THIS CHART IS ONLY A GUIDE AND SHOULD NOT BE USED TO OPERATE THE CRANE. The individual crane's load chart, operating instructions and other instructional plates must be read and understood prior to operating the crane.

GMK5275

GROVE

load charts

20



223 ft.
(68 m)



39.4-68.9-95.1-121.4 lbs.
(12-21-29-37 m)



90,300 lbs.
(41,000 kg)



100%
26'-7" spread



360°



Pounds (thousands)

Radius	223' + 39.4'			223' + 68.9'			223' + 95.1'			223' + 121.4'		
	5°	5°-20°	20°-40°	5°	5°-20°	20°-40°	5°	5°-20°	20°-40°	5°	5°-20°	20°-40°
	x 1000 lb.											
45	16.4											
50	16.4	16.4		10.0								
55	16.4	16.4		10.0			7.4					
60	16.4	16.4	16.4	10.0			7.4			5.0		
65	16.4	16.4	16.4	10.0			7.4			5.0		
70	16.4	16.4	16.4	10.0	10.0		7.4			5.0		
75	16.4	16.4	16.4	10.0	10.0		7.4	7.4		5.0		
80	16.4	16.4	16.4	10.0	10.0		7.4	7.4		5.0	5.0	
85	16.4	16.4	16.0	10.0	10.0		7.4	7.4		5.0	5.0	
90	16.4	16.2	15.6	10.0	10.0	9.4	7.4	7.4		5.0	5.0	
95	16.4	15.8	15.2	10.0	10.0	9.4	7.4	7.4	7.2	5.0	5.0	4.0
100	16.0	15.2	14.8	10.0	10.0	9.2	7.4	7.4	7.2	5.0	5.0	4.0
105	15.6	14.8	14.4	10.0	10.0	9.2	7.4	7.4	7.2	5.0	5.0	4.0
110	15.0	14.4	14.0	10.0	10.0	9.2	7.4	7.4	7.2	5.0	5.0	4.0
115	14.4	13.8	13.6	10.0	10.0	9.0	7.4	7.4	7.2	5.0	5.0	4.0
120	13.8	13.4	13.2	10.0	10.0	9.0	7.4	7.4	7.2	5.0	5.0	4.0
125	12.6	12.6	12.8	10.0	10.0	9.0	7.4	7.4	7.2	5.0	5.0	4.0
130	11.6	11.6	12.4	10.0	9.8	8.8	7.4	7.4	7.2	5.0	5.0	4.0
135	10.4	10.4	11.2	10.0	9.6	8.8	7.4	7.4	7.2	5.0	5.0	4.0
140	9.4	9.4	10.2	9.8	9.4	8.8	7.4	7.2	7.0	5.0	5.0	4.0
145	8.6	8.6	9.2	9.4	9.0	8.6	7.4	7.2	7.0	5.0	5.0	4.0
150	7.6	7.6	8.4	8.6	8.6	8.6	7.4	7.0	6.8	5.0	4.8	4.0
155	6.8	6.8	7.4	7.8	7.8	8.4	7.2	6.8	6.6	5.0	4.8	4.0
160	6.0	6.0	6.6	7.0	7.0	8.2	6.8	6.6	6.6	5.0	4.8	4.0
165	5.4	5.4	6.0	6.2	6.2	7.4	6.2	6.2	6.4	4.8	4.8	4.0
170	4.8	4.8	5.2	5.6	5.6	6.6	5.4	5.4	6.2	4.8	4.6	4.0
175	4.0	4.0	4.6	5.0	5.0	6.0	4.8	4.8	6.0	4.6	4.6	4.0
180	3.4	3.4	4.0	4.4	4.4	5.4	4.2	4.2	5.2	4.0	4.0	4.0
185	2.8	2.8	3.4	3.8	3.8	4.6	3.6	3.6	4.6	3.6	3.6	4.0
190	2.4	2.4	2.8	3.2	3.2	4.0	3.2	3.2	4.0	3.0	3.0	4.0
195			2.2	2.8	2.8	3.6	2.6	2.6	3.6	2.6	2.6	3.4
200				2.2	2.2	3.0	2.2	2.2	3.0	2.0	2.0	2.8
205						2.4			2.4			2.4
210						2.0			2.0			2.0

GMK5275

GROVE

THIS CHART IS ONLY A GUIDE AND SHOULD NOT BE USED TO OPERATE THE CRANE. The individual crane's load chart, operating instructions and other instructional plates must be read and understood prior to operating the crane.

working range

Heavy Duty Jib – 6.6 ft.

21

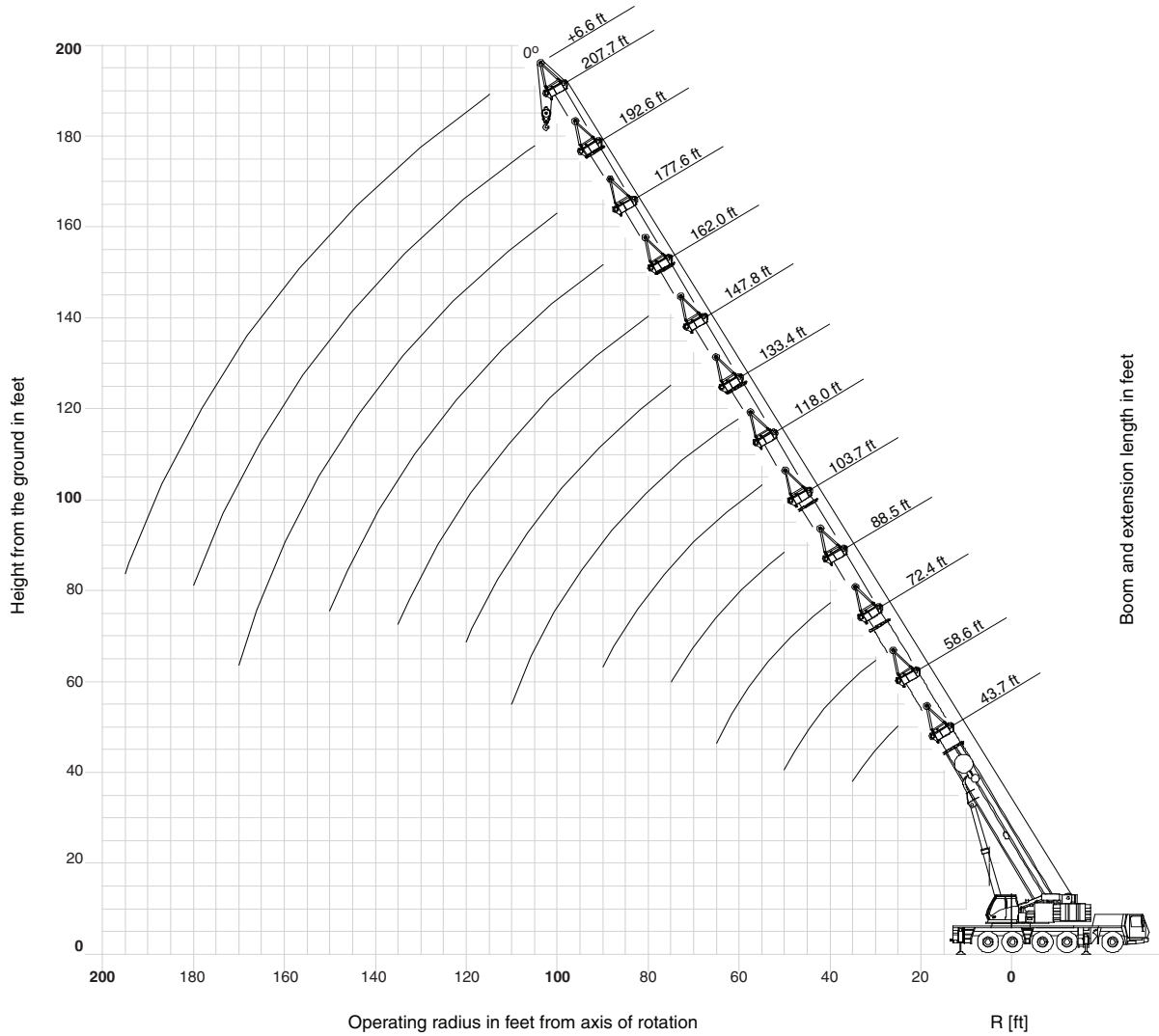

THIS CHART IS ONLY A GUIDE AND SHOULD NOT BE USED TO OPERATE THE CRANE. The individual crane's load chart, operating instructions and other instructional plates must be read and understood prior to operating the crane.

GMK5275

GROVE

working range

Heavy Duty Jib – 6.6 ft.

22

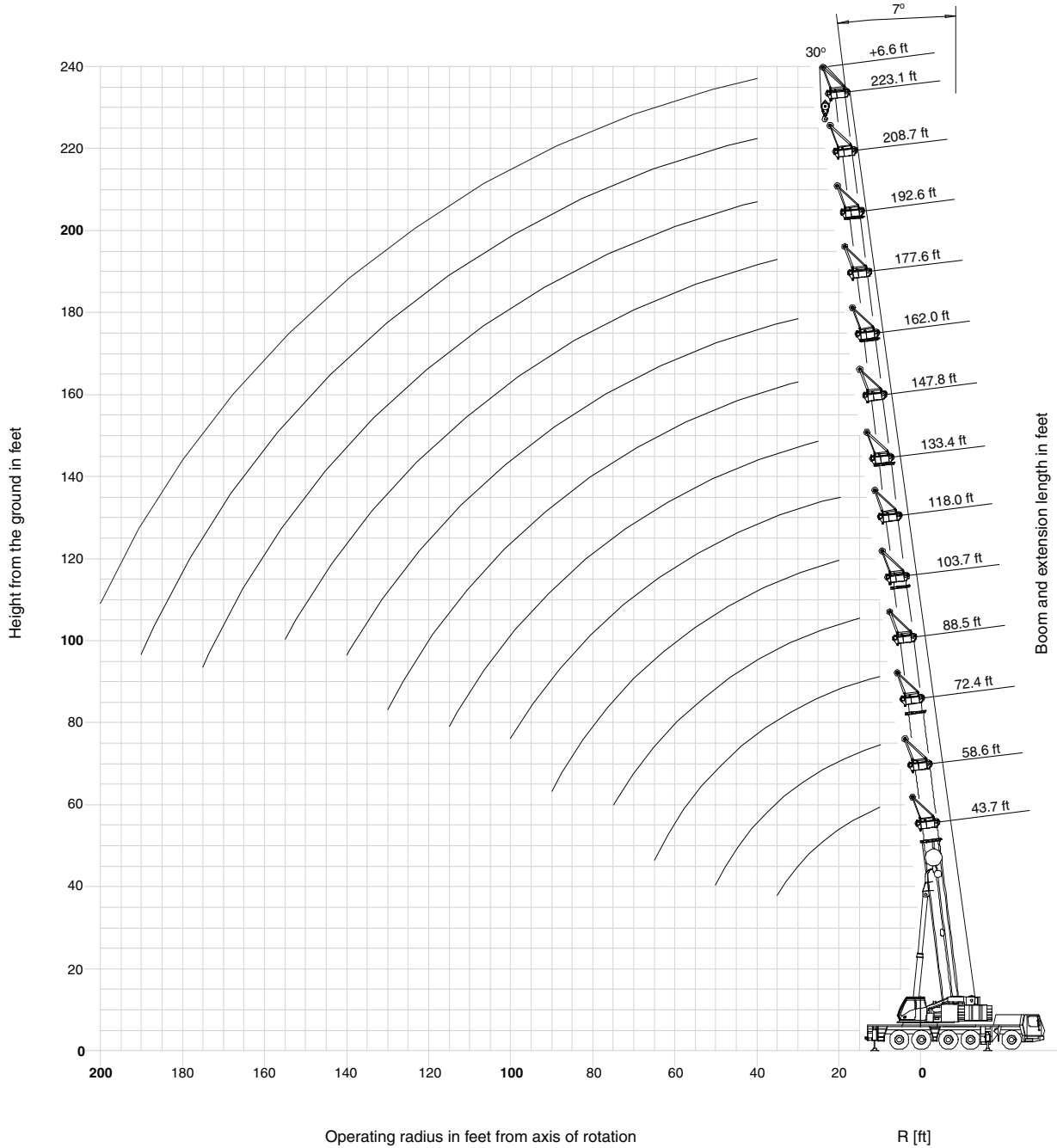

GMK5275

GROVE

THIS CHART IS ONLY A GUIDE AND SHOULD NOT BE USED TO OPERATE THE CRANE. The individual crane's load chart, operating instructions and other instructional plates must be read and understood prior to operating the crane.

load charts

44-223 ft.
(13.3-68 m)

6.6 ft.

169,700 lbs.
(77,000 kg)

100%
26'-7" spread

360°

23



Pounds (thousands)

Radius	43.7' + 6.6'		88.5' + 6.6'		133.4' + 6.6'		177.6' + 6.6'		223' + 6.6'	
	0°	30°	0°	30°	0°	30°	0°	30°	0°	30°
10		41.8								
15		41.8		41.8						
20		41.8		41.8						
25	41.8	41.8		41.8		41.8				
30	41.8	41.8		41.8		41.8				
35	41.8	41.8		41.8		41.8		41.8		
40				41.8		41.8		41.8		25.0
45				41.8		41.8		41.8		25.0
50			41.8	41.8		41.8		41.8		25.0
55			41.8	41.8		41.8		41.8		25.0
60			41.8	41.8		41.8		41.8		25.0
65			41.8	41.8		41.8		41.8		25.0
70			41.8	41.8		41.8		41.0		25.0
75			41.8	41.8	41.8	41.8		38.8		25.0
80					41.8	41.8		36.6		25.0
85					41.8	41.8		34.4		25.0
90					41.8	41.8		32.4		25.0
95					41.8	41.8		30.4		25.0
100					41.0	41.4	22.8	28.6		24.2
105					37.8	38.2	21.0	26.8		22.8
110					34.8	35.2	20.0	25.2		21.4
115					32.2	32.6	19.2	23.8		20.0
120					28.6		18.4	21.6		19.2
125							17.6	19.8		18.2
130							16.8	18.6		17.4
135							16.2	17.6		16.6
140							15.6	16.6		15.8
145							15.0	15.8		15.0
150							14.4	15.0		14.4
155							14.0	14.2		13.8
160							13.4			13.2
165							13.0			12.6
170							12.2			12.0
175										11.4
180										10.8
185										10.4
190										9.8
195										9.4
200										8.8

GMK5275

THIS CHART IS ONLY A GUIDE AND SHOULD NOT BE USED TO OPERATE THE CRANE. The individual crane's load chart, operating instructions and other instructional plates must be read and understood prior to operating the crane.

GROVE